

# 4 IN 1 INSTANT BOILING CHILLED WATER TAP

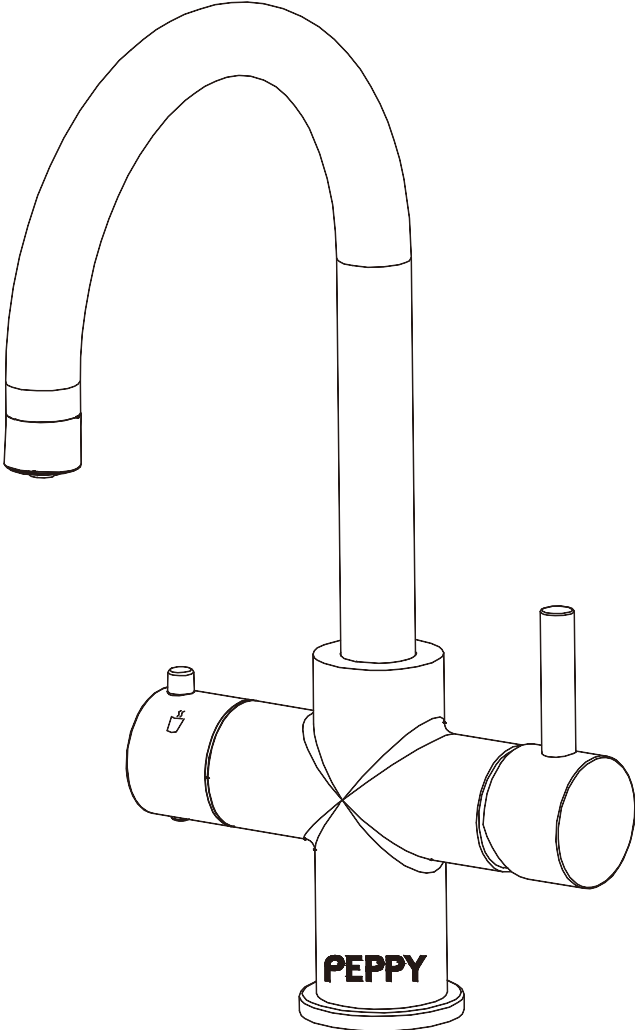

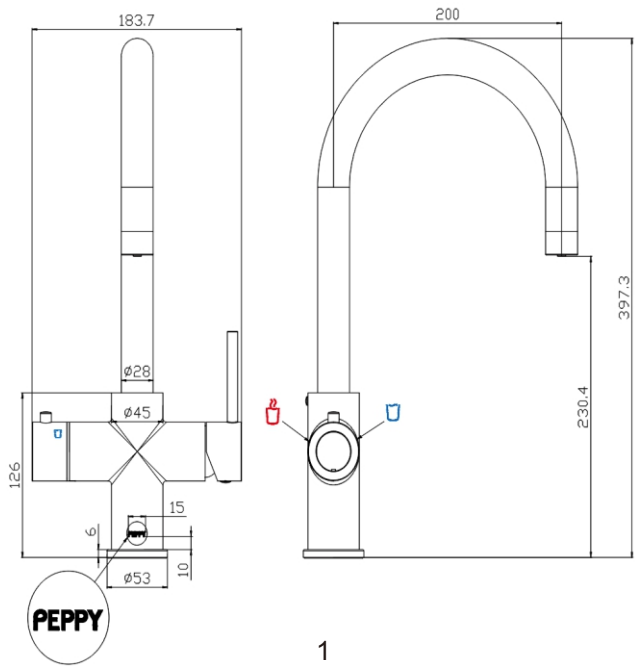

Hole size in Bench for tap is 35mm

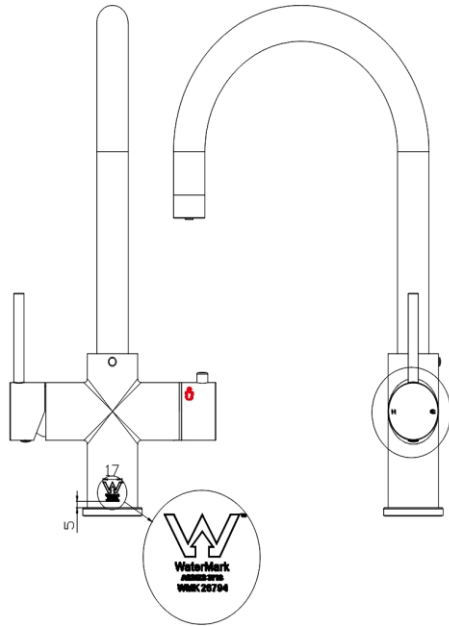
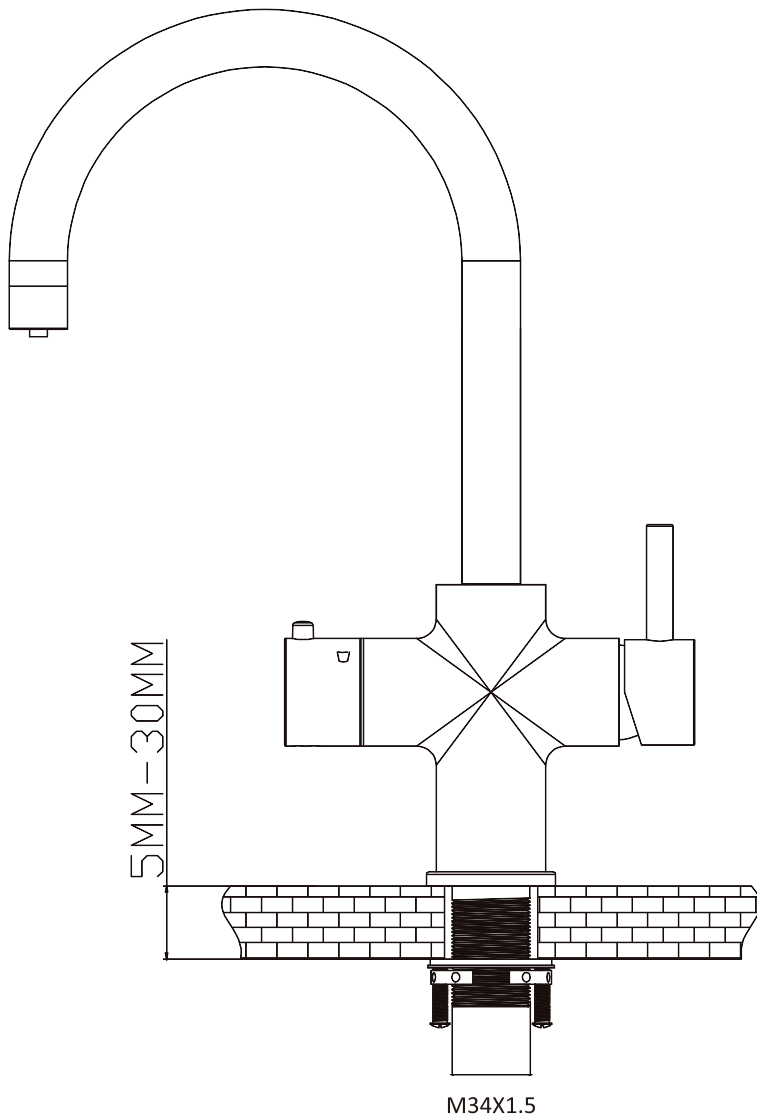

No	Part Description	Qty	Size
A	TAP	1	
B	O-ring	1	
C	Rubber Washer	1	47*32.5*3
D	Metal Washer	1	
E	Mounting nut	1	32*1.5
1	Cold flexible hose	1	M8*1-3/8"thread
2	Hot flexible hose	1	M8*1-1/2"thread
3	Hose from T adaptor to tap	1	M8*1-Ø1/4" quick fit
4	Hose from Chiller outlet to tap	1	M8*1-Ø1/4" quick fit
5	Hose from tap to boiler inlet	1	M8*1-3/8"thread
6	Hose from boiler outlet to tap	1	M8*1-3/8"thread
7	Hose from cold water supply to pressure limiting valve	1	3/8"thread-Ø1/4"quick fit
8	PE hose from filter protective valve to filter inlet	1	Ø1/4"
9	PE hose from filter outlet to T adaptor	1	Ø1/4"
10	PE hose from T adaptor to Leak Detector IN Port	1	Ø1/4"
11	PE hose from Leak Detector out Port to Chiller Filtered Water In	1	Ø1/4"
12	PE hose from chiller wastewater out to waste pipe	1	Ø1/4"
13	Brass three way connector	1	1/2"female*3/8"male*3/8"male
14	1/4" quick fit T-adaptor	1	Ø1/4" quick fit
15	Pressure Limiting Valve	1	Ø1/4" quick fit
16	Neoperl flow limiter	2	
17	Saddle drain	1	Ø1/4" quick fit
18	Leak Detector,Auto-shut off Valve	1	Ø1/4" quick fit

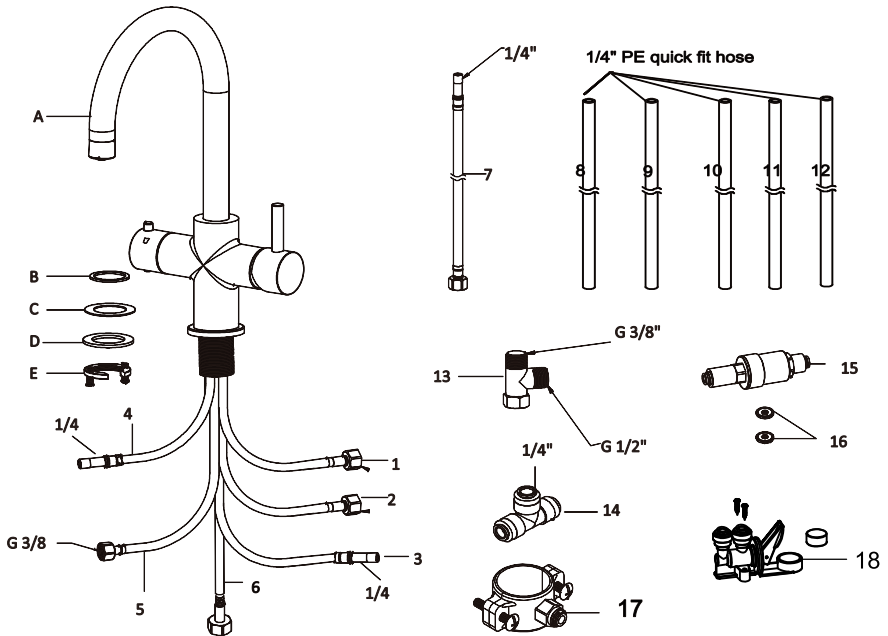

**Note:**

The boiler & chiller have dedicated power connecti ons. To run the 4 in1 tap with boiler & chiller, you will need a dedicated 10Amp Dual power point

Product must be installed in accordance with AS/NZS 3500:1 and AS/NZS 3500:2 INSTALLATION MUST BE AS THE PLUMBING CODE OF AUSTRALIA

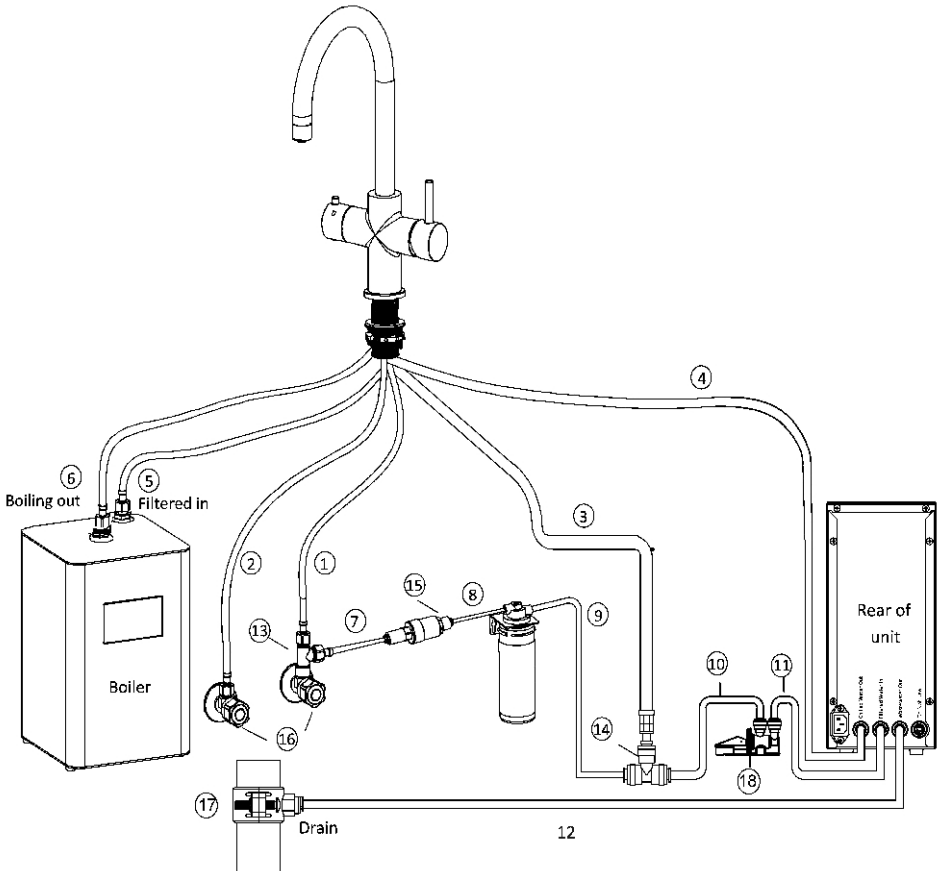

Leak Detector must be installed between T-adaptor and Chiller Port' Filtered Water In'. Use two 1/4" hoses where diagram shows

If the user only needs boiling water, filtered water connect hose(4) onto T adaptor(13)

Note:The boiler has a dedicated power connections.To run the 4 in1 tap with boiler you will need a dedicated 10 Amp dual power point.

Product must be installed in accordance with AS/NZS 3500:1 and AS/NZS3500:2 plumbing code of Australia and New Zealand.

Note:The use of this may increase bacterial content of the water unless supplementary treatment is provided.

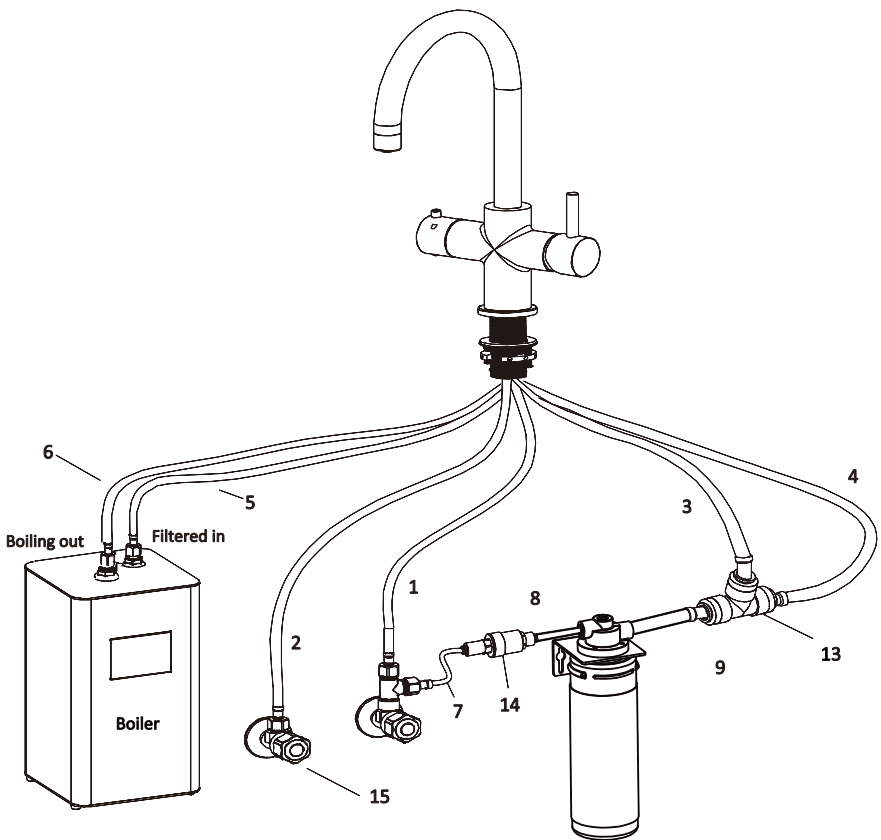

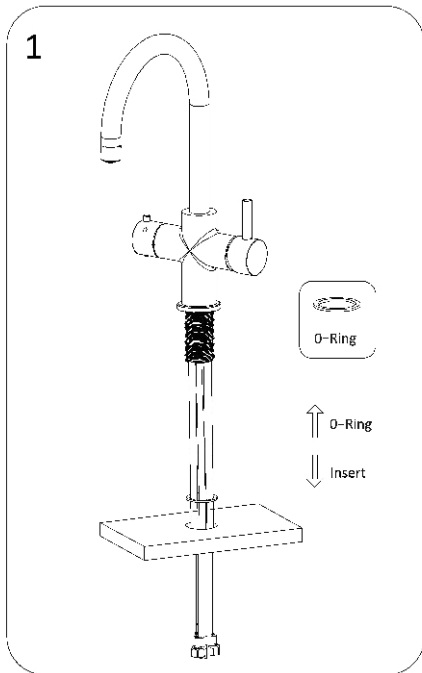

1.Insert the O-ring(B)over the hoses into tap shank,and mount the tap on the sink /Benchtop,See Fig.1

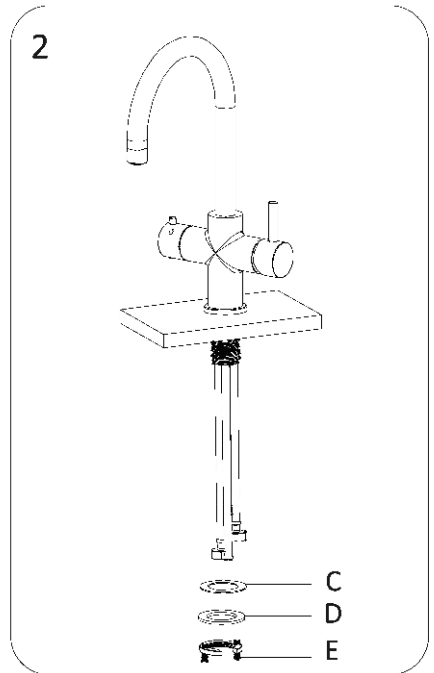

2.Slide the rubber washer(C) firstly, metal washer(D) Secondly, then the mounting nut(E) over the hoses onto the stem, and tighten them firmly, See Fig.2

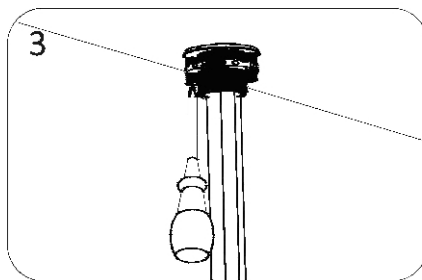

3. Use a Phillips head screwdriver to tighten the 2 screws.See Fig3

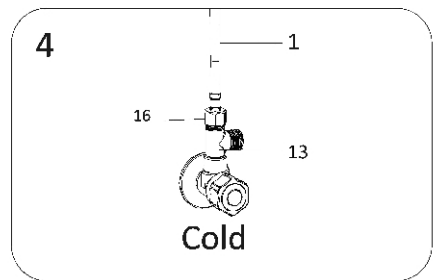

4.Put flow limiter(16)into Flex hose(1), then connect cold flexible hose(1)& brass three way connector(13) onto the cold matching water valves and secure the connection with an adjustable wrench. See Fig4

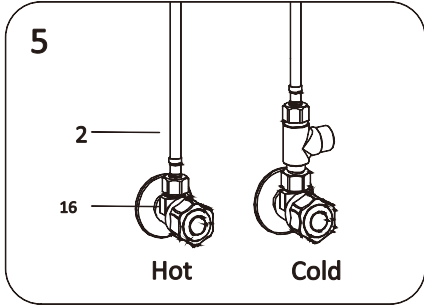

5. Connect the hot flexible hose (2) onto the hot matching water valve, and secure the connection with an adjustable wrench. See Fig 5

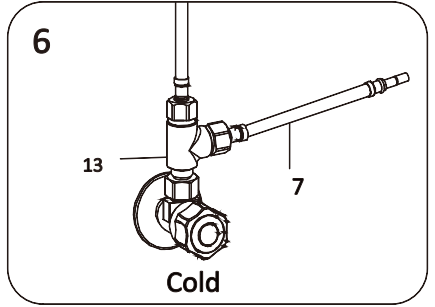

6. Connect hose (7) onto brass three way connector (13) and tighten firmly with a spanner. See Fig. 6

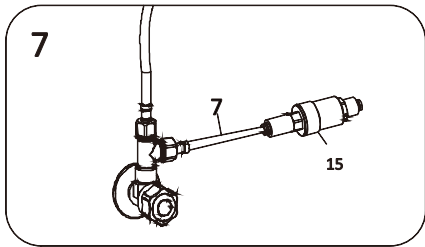

7. Connect hose (7) onto the pressure limiting valve, See Fig 7.

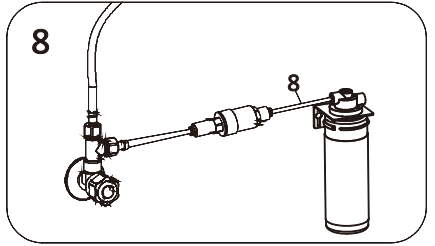

8. Connect hose (8) onto the pressure limiting valve and the other side to filter inlet. See Fig 8

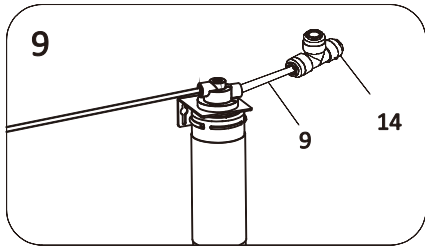

9. Connect hose (9) onto T-adaptor, See Fig 9

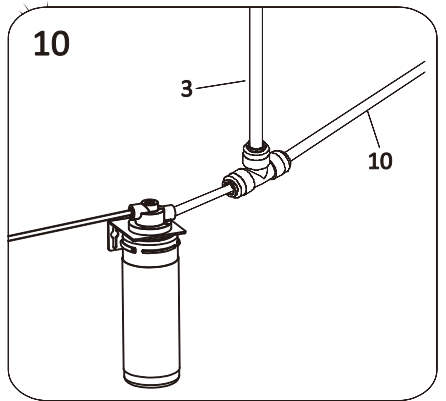

10. Connect hose (3) & hose (10) onto T-adaptor, See Fig 10

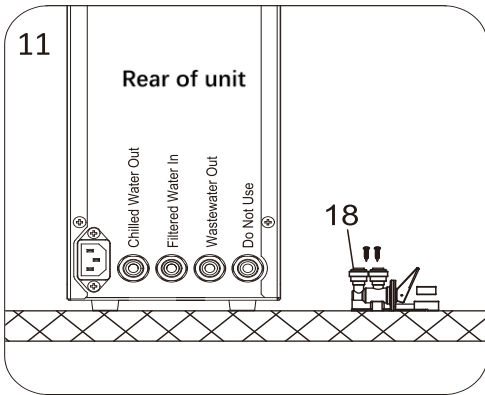

11. Mount the Leak Detector onto the surface area in your cabinet ; Put the compressed textile, see fig. 11

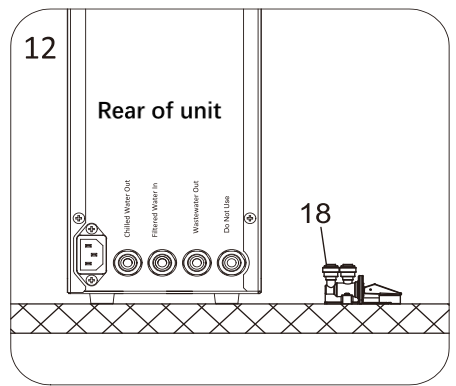

12. Close the cover after putting in the compressed textile, see fig. 12

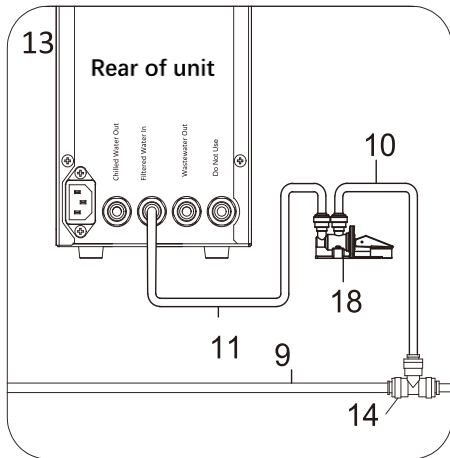

13. Connect 6mm dia hose on both Leak Detector IN&OUT, and hose(11) to Chiller Filtered Water In port, see fig. 13

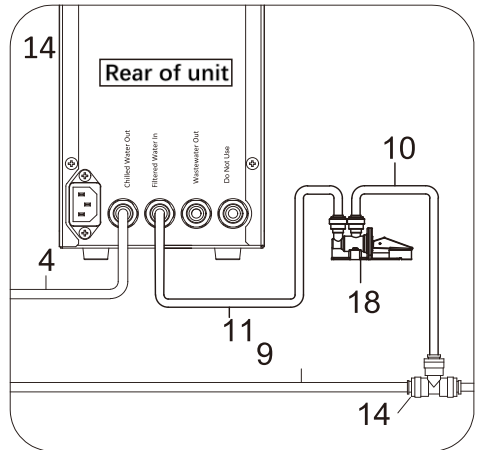

14. Connect 6mm dia hose (4) supplied to Chiller Water Out Port, see fig. 14

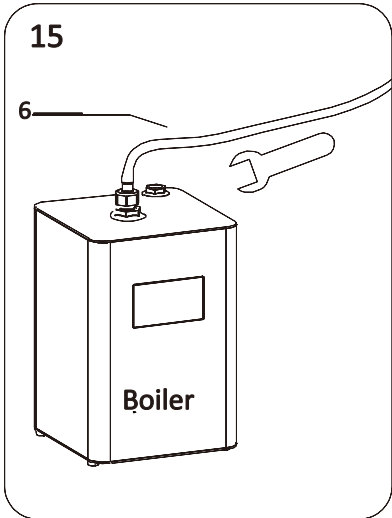

**15.** Connect hose(6) onto boiler'outlet(red nut) then secure the connection, See Fig15  
**Note:**As This Is An Open Vented Design It Is Critical That This Hose Remain Open To The Atmosphere And Is Not Obstructured

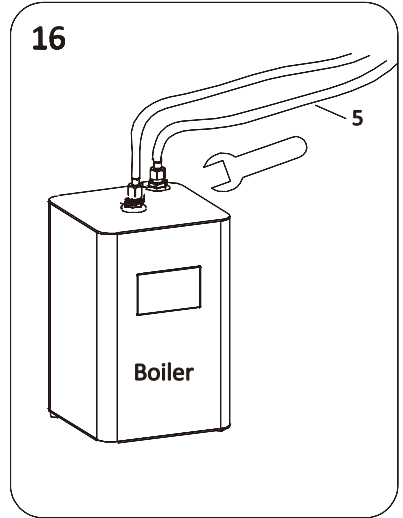

**16.** Connect hose(5) onto boiler'inlet(blue nut) then secure the connection, See Fig16

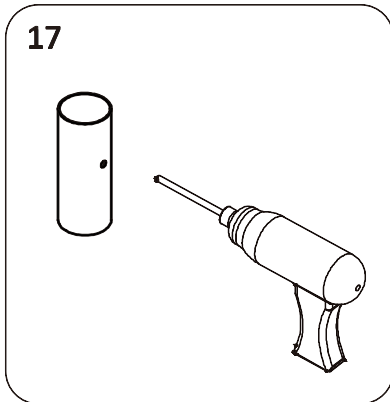

**17.** See Fig17, Use a drill to drill a 5.5mm diameter hole on the waste drainage pipe.

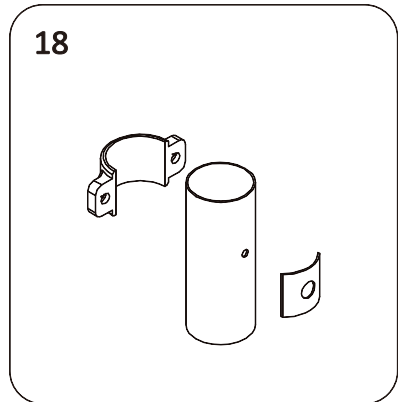

**18.** See Fig18, Put drain saddle'back and front plate onto the pipe

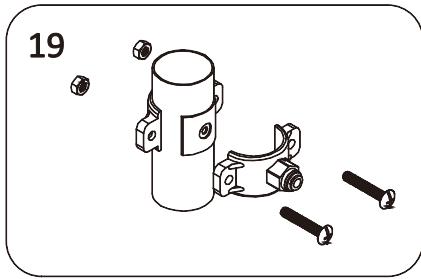

19. See Fig 19, Insert screws and tighten

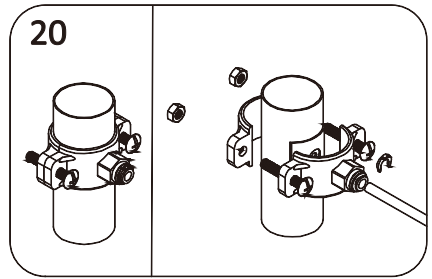

20. See Fig 20,  
After Securing the screw and nut onto saddle drain plate Insert a 6mm white PE tube.

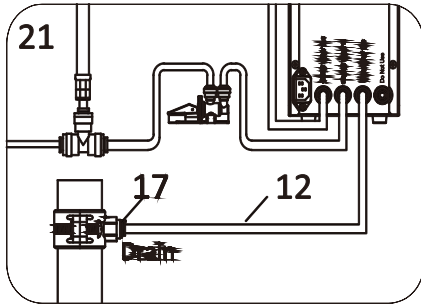

21. Connect 6mm dia hose (11) supplied from Saddle drain (17) to Chiller' To drain Connector

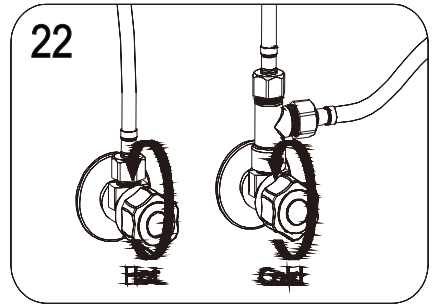

22. Turn on the water supply and check on the water connection. Test system for leaks, and purge system. Run a minimum of 20 liters (5min) water through. Note: Isolation valves MUST be installed on the hot and cold mains water supply for servicing and maintenance

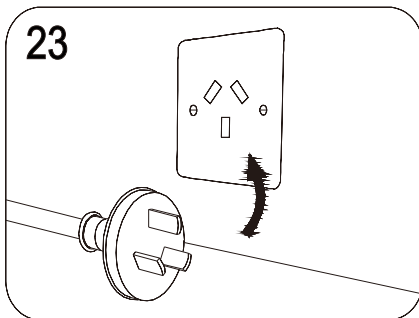

23. Do not turn on Power until step 22 is complete. You must run water through the filtered Ambient side to clear filter for 5 minutes. Then fill Boiler (hold down the boiler handle until water comes out of the tap indicating the boiler is full.) Then plug in and turn on

Note:How The Open Vented Design Works

WARNING: OPEN VENT IS NOT TO BE BLOCKED UNDER ANY CIRCUMSTANCES AND MUST REMAIN OPEN.

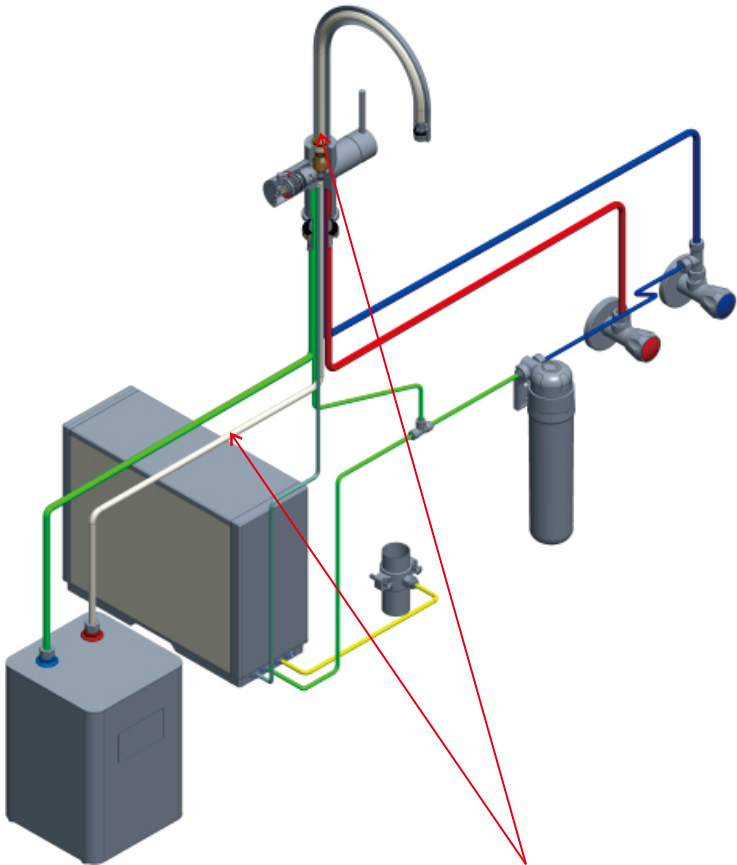

Grey pipe marked here is open vent pipe to allow boiling water flowing, and air to leave tap

Note: Installation Must Be As The Plumbing Code Of Australia

## COMMISSIONING

It is the installer's responsibility to ensure that your 4 in 1 Instant Boiling Water Tap is fitted following all prevailing national standards and local water laws. It is important to ensure that the plumbing part of the installation is completed and has been tested to ensure it is free of leaks before any electrical connection is made to the unit. Do not install the appliance in rooms where the temperature may drop to 0°C. The Tap or Boiling Water Tank has been stored prior to installation in a place where the temperature could have fallen below 0°C, Allowed to acclimatise at room temperature for a minimum of one hour prior to connection to a water supply.

Before installing the 4-1 instant boiling water tap it is essential to thoroughly flush through the supply pipes in order to remove any impurities from your system. Failure to carry out this simple procedure could cause problems or damage.

**NOTE:** Minimum supply pressure for the cold water is 150 KPA and maximum is 500 KPA

You must install isolation valves to both the hot and cold feed pipes in an accessible position. This will help prevent premature failure and ease any future maintenance. All parts should be removed from their packaging and inspected prior to installation.

This hot water tap requires a 35mm diameter tap hole; if replacing an existing tap, remove the old tap & clean the ends of the feed pipes using wire wool; the tap hole area should also be free from dirt and sealant.

**WARNING**-Failure to Install Leak Detector Could Result In Damange And Will Void Warranty

### Positioning the Boiling Water Tank unit and the filter

- The reservoir/heater unit should be positioned on a flat level surface such that:
- There is a minimum air-space of 150mm to each side of the reservoir/heater unit.
- There is a minimum air-space of 25mm to the rear of the reservoir/heater unit.
- Access to any stopcocks, valves, waste traps or other plumbing fittings that may require service is not impeded.

## **The front display and operating controls are readily accessible and visible.**

1. All pipes can be installed without stretching or twisting them.
2. Access to the electrical power socket to be used for this appliance is not restricted.
3. Ensure a fused 10AMP power supply within reach of the power cable, Ensure cable is not stretched. If it is necessary to extend the power cable to reach the nearest suitable socket, this must be done by an electrician. A double GPO will be needed if you are installing a Boiler & Chiller, The tap also requires a GPO for operation.
4. The filter should be mounted in a convenient location on a wall or cabinet side, taking into consideration the length and routing of the connecting hoses.

## **Boiler and Chiller Operation**

**DO NOT SWITCH ON THE HOT WATER TANK OR CHILLER at this stage until the following has been carried out.**

1. Run the FILTERED COLD WATER for a minimum of 5 minutes to activate and clean the carbon agency inside the Anti-scaling filter before starting the Hot Water Tank.
2. Then Run BOILING WATER for a minimum of 5 minutes.

By taking this small step will prevent any carton dust from the filter. If there is any Black coloured water, it is harmless and it will clear itself by running the water.

Open all installed water vavles to allow water to flow to the 4-1 instant hot water tap.

For the boiler, Turn the spring-back hot water tap handle against its spring and hold there until the water flows from the tap spout which indicates the taps reservoir is full.

Allow the hot water handle to spring back to its rest position and check all the connections for water tightness and absence of leaks.

Any leaking joints must be tightened and the surrounding area dried before connecting the power supply.

ONLY connect the electricity supply to the Hot Water Tank at this stage. Insert the plug into the electricity socket and switch on.

**Warning-**Ensure Leak Detector is installed and screwed down to cabinet base next to Chiller before operating the Chiller

## How to control the INSTANT BOILING WATER TANK

- A: On/Off Key
- B: Temperature Key
- C: Heating Display
- D: Set Temperature Indicator
- E: Actual Temperature Indicator
- F: Filter Life Indicator

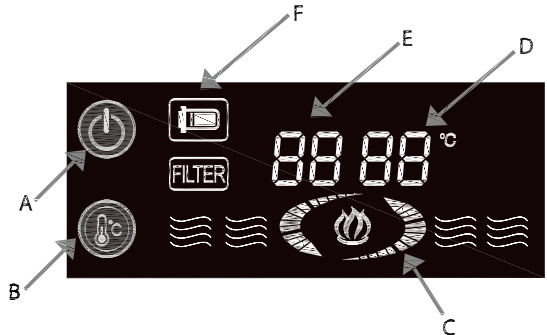

Touch the “on/off” key (A) once to switch the heater on. Press again to turn off.

Scroll through temperature settings using temperature key (B), leave on desired temperature, indicator will flash three times and set temperature indicator (D). Filter life indicator (F) will appear when it is time to change your filter.

A reminder will sound after 6 months and again after 12 hours from the first sound to reset, replace your filter and hold the temperature key (B) for 10 seconds until a single beep sounds and the filter logo will return to full. KEYS At all times, the “Actual Temperature” indicator (E) shows the actual temperature of the water in the Boiling Water Tank. When the water is heating up, indicator (C) will illuminate and the “Heating” Display (C) will animate. Care and Maintenance Important:

**The Warranty Is Void If The Water Filter Is Not Replaced At A Minimum Of 12(twelve) Months From Its First Use. If The System Is Use In The Hard Water Area, Customer Should Consider To Replace The Water Filter In A Shorter Period Before The Twelve Months Period.**

**Warning-Warranty Is Void If Leak Detector Not Installed On Chiller.**

Do Not Perform Maintenance Or Cleaning Of The Boiling Water Tank Without First Switching Off The Electricity Supply. Cleaning Should Be Carried Out With A Non-abrasive Cleaner. Any Abrasive Cleaner (including Cif) Will Scratch The Surface And Could Erase The Marking. Exterior Of Your Boiling Water Tank Can Be Cleaned Effectively By Using A Damp Cloth And Mild Detergent. Finish Off By Drying With A Clean Cloth.

Replacement Filters available through retailer

**WARRANTY IS VOID IF LEAK DETECTOR NOT INSTALLED ON CHILLER**

# SPECIFICATIONS

Supply	230V ~ 50Hz	Information For Correct Disposal Of The Product In Accordance With The Directive 2002/e.
Power	1500W	
IP rating	X4	At The End Of Its Working Life This Equipment Must Not Be Disposed Of As Household Waste.it Must Be Taken To A Local Authority Waste Collection Centre Or To A Dealer Providing This Service.disposing Of Electrical And Electronic Equipment Separately Enables Its Components To Be Recovered And Recycled To Obtain Significant Savings In Energy And Resources. In Order To Underline The Duty To Dispose Of This Equipment Separately, The Product Is Marked With A Crossed Out Dustbin.
Tank Capacity	2.4 litres	
Immediate draw off	1.7 litres	
Minimum supply pressure	0.15 MPa (1.5 bar)	
Maximum supply pressure	0.5 MPa* (5 bar)	
Hot and cold connections	3/8" BSP	
Approvals	RCM,CE	

\*If pressure is above 0.5Mpa(5bar) then a pressure reducing valve is required.

## Guarantee

**This product is covered by a standards parts & replacement warranty from purchase for 2 years.**

**If there is a manufacturing defect within the warranty period, we will send spare parts, repair and return the unit or supply a replacement at our discretion. Incorrect installation, frost damage, the consequences of limescale deposits or failure to follow correct commissioning, operating & maintenance instructions are excluded. Consequential costs such as labour charges or damage to fittings and surroundings are expressly excluded.**

**NOTE: We will not warrant tank water installations. Must be installed via mains water only.**

**Filter must be changed at a minimum every 12 months and must be too a specified Peppy Taps filter. If not the warranty is void.**

**Leak detector must be installed on all models with a chiller.**

**Commercial warranty is 12 months parts & labour.**

**If you experience an issue with this product you should firstly contact our service department before taking further action. Experience has shown that issues can often be resolved without the need to return or uninstall the product.**

**Scope of Use to indicate compliance with the Lead-Free requirements of the National Construction Code Volume 3.**

# Important Notice On Boiler

Caution: Do Not Use With Water That Is Microbiologically Unsafe Or With Water Of Unknown Quality Without Adequate Disinfection Before Or After The System. Systems Certified For Cystreduction May Be Used On Used On Disinfected Water That May Contain Filterable Cysts  
This Product Can Cause Harm If Installed Incorrectly, The Installation Of Your Instant Hot Water Tap Must Be Carried Out By A Professional Installation Service.

## SAFETY INSTRUCTION



**Alert symbols identify important safety information to make you aware of potential hazards that can cause property damage or in the severest cases, serious injury or death.**

This product is not for outdoor use!

A standard 220/240v grounded 10amp switched electrical outlet is required under the sink for the appliance electrical power

The power outlet must be connected to the 10amp fused plug supplied.

Do not plug in the tank until all water connections have been checked, watertight and the tank has been filled. The tank is filled once water starts to pass out the tap spout.

It is recommended before using the tank, to flush through several litres of water to remove any air in the system when installing.

Please note, that in order to avoid having pressurized boiling water and to comply with Australian bylaw, this is an open vented system. In order to ensure the instant hot water tank delivers the highest quality drinking water and is protected from limescale build up, the water filter must be replaced every 12 months. Failure to do so may invalidate your product warranty.

The instant hot water tank is only intended for use with compatible taps. Using this tank with any other tap will invalidate the warranty.



Warning-for Continued Safety Of This Appliance It Must Be Installed, Operated And Maintained In Accordance With The Manufacturer's Instructions.

For Open Vented Water Heaters, An Instruction That Any Vent Or Outlet Intended To Remain Open To The Atmosphere Shall Not Be Obstructed.

For Controlled Water Heaters, The Rated Power Input, In Kilowatts, Or The Total Nominal Gas Consumption In Megajoules Per Hour, As Appropriate.

For Uncontrolled Water Heaters(e.g.storage, Auxiliary),maximum Working Pressure, In Kilopascals, And Maximum Energy Input, In Kilowatts Or Megajoules Per Hour.

For Auxiliary Uncontrolled Water Heaters, Maximum Rated Output, In Kilowatts Or Megajoules Hour.

Warning-this appliance May Deliver Water At High Temperature, Refer To The Plumbing Code Of Australia(pca) or New Zealand, Local Requirements and Installation Instructions To Determine If Additional Delivery Temperature Control Is Required.



- + To prevent against electrical shock do not place the hot water tank near or in water or other liquids and install on a flat surface.
- + Do not install in environments above 35°C or exposed to freezing.
- + Can be used by children 12+ or people with learning difficulties if they have been given supervision or instructed on the hazards involved. Do not operate or install electrical connections with wet hands.
- + Do not install the appliance if it appears damaged in any way.
- + Only use power lead supplied with the product. If the power lead is damaged, stop using immediately and contact customer services for a replacement.
- + Do not remove tank casing, this product is not serviceable and should be returned to the manufacturer in the event of a fault.
- + Do not modify the tank or remove the plug as this will invalidate the warranty and could cause serious injury. Designed for Australian 3 pin socket only.
- + If the unit is unused for extended periods of time it should be unplugged, drained, re-filtered and refilled.
- +The external casing can be cleaned with a lint free damp cloth.Do not use any abrasive or corrosive cleaning products as this will damage the surface of the product.
- + Replace the filter every 12 months

# Important Notice On Boiler

Below is a list of some of the possible malfunctions.  
If the problem cannot be resolved as described, contact the dedicated customer care line(details on back cover).

PROBLEM	POSSIBLE CAUSE	WHAT TO DO
"Set temperature"indicator flashed "E3"	Insufficient water in the tank	Prime the installation as described in the installation instruction below
Water and Steam is spitting from the instant hot water tap spout.	Unit is boiling.	Turn the instant hot water tap handle on and release the water. Adjust the water temperature on the display to a lower setting. Check Aerator not blocked.Re-Prime Bladder to allow correct operation.
Water is not hot.	The electronic instant hot water appliance is unplugged. The electronic display has not been powered up.	Turn the instant hot water tap handle on and release the water. Adjust the water temperature on the display to a lower setting. Check Aerator not blocked.Re-Prime Bladder to allow correct operation.
Water is too hot.	Water temperature setting on display panel is set to high.	Re-set the temperature to the required temperature and confirm the heating up
Water is dripping from the instant hot water tap spout.	The expansion chamber isn't draining the system correctly due to very small draw off of water.Blockage/Restriction after tank.	Draw off 0.5L of water to clear and prime the system. Avoid less than 150ml draw offs of water. Check for kinks in silicon tube. Ensure silicon tube is cut to optimum length. Remove and clean the aerator.
Slow Flow from the spout.	The water filter maybe clogged from impurities in the inlet mains water Blockaged/Restriction after tank.	The water filter must be changed every 12 months Failure to do this may invalidate your warranty. Draw off 0.5 of water to clear and prime the system. Avoid less than 150ml draw offs of water. Remove and clean the aerator
Water does not flow immediately	The electronic instant hot water appliance is designed for non-pressurised operation and there will be slight delay till the near boiling water appears.	After a large volume of water has been drawn off there may a slightly longer delay in the water appearing from the instant hot water tap spout.
No Water flows.	Water valves have been turned off. Inlet pipes have become twisted or blocked.	Turn on all the water valves. Ensure the pipes are not twisted or kinked to restrict the flow.
E4		Please call Peppy Taps AUS: 0391220716 NZ: 0800434756

Do Not Perform Maintenance Or Cleaning Of The Boiling Water Tank Without First Switching Off The Electricity Supply. Cleaning Should Be Carried Out With A Non-abrasive Cleaner. Any Abrasive Cleaner (including Cif) Will Scratch The Surface And Could Erase The Marking. Exterior Of Your Boiling Water Tank Can Be Cleaned Effectively By Using A Damp Cloth And Mild Detergent. Finish Off By Drying With A Clean Cloth.

How To Control The Use The Chiller Unit (skip If You Have Not Installed A Chilled Water Unit)

## How To Use Chiller Unit

Display panel
"A" (Display panel"on/off"icon) Press and power on or off
"B" icon to raise to next preset temperature , Temp range: 4°C~14°C
"C" LED flash, it is flashing when running, it is solid when cooling done "D" : to show the actual temperature "E" :to show the setting temperature



## How To Use The 4 in 1 Hot Tap Filtered Boiling Water

The Left Side Of The Tap Keep The Small Lock Button Pressed Down And Rotate The Knob Forwards (away From You) And Boiling Water Will Come Out At The Set Temperature. Let Go And Will Spring Back To The Off Position, Boiling Water Will Stop.

For Filtered Chilled/filtered Ambient Water - Left Side Of The Tap Rotate The Knob Towards You. There Is No Need To Push Down The Safety Lock Button And Either Filtered Chilled Or Filtered Ambient Water Will Come Out Depending On Which Feature You Have Chosen.

For Mixed Mains Water, Pull The Large Tap Lever On The Right Hand Side Away From The Body For Cold Water And Towards Yourself For Cold Mains Water.

These Instructions Are Only Intended As A Guide, If There Is Any Doubt Then Contact A Certified Plumber Or Service Agent And Avoid Using The Instant Hot Water System Until It Has Been Checked

## Appliance structure

### Front view

No	Model: Undercounter chill unit
1	Top lid
2	Touching display panel
3	Chilled Water Out
4	Filtered Water In
5	To Drain Connector
6	Do Not Use
7	Appliance outcase

### Image

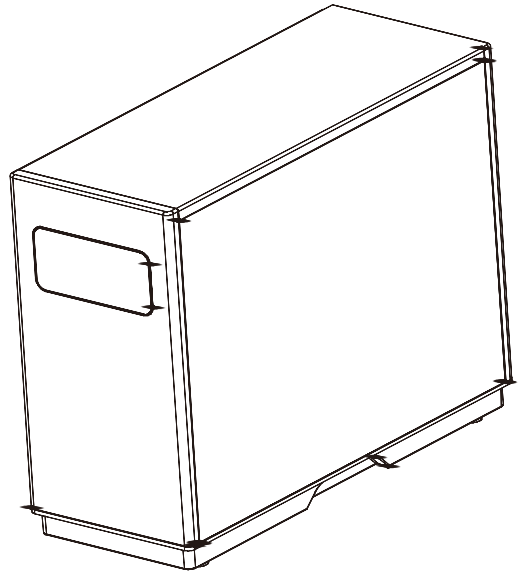
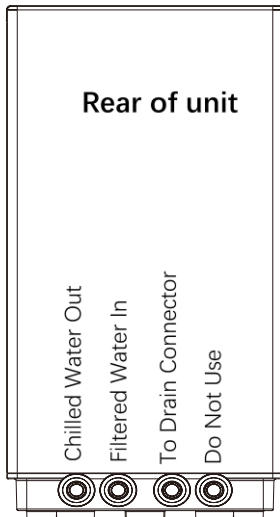

## Important Notice On Boiler and Chiller

### 1. Safety notes

- 1) This appliance is not intended for use by persons(including children) with reduced physical or mental capabilities, or lack of experience and knowledge, unless they have been given supervision or instruction concerning use of the appliance by a person responsible for their safety.  
**Note: Children should be supervised to ensure that they do not play with the appliance.**
- 2) If the supply cord is damaged, it must be replaced by the manufacturer, its service agent or similarly qualified persons in order to avoid a hazard.
- 3) The instructions for appliances connected to the water mains by detachable hose-sets shall state that the new hose-sets supplied with the appliance are to be used and that old hose-sets should not be reused.

### 2.Product use

- 1).The Chiller is only suitable for indoor use.
- 2) Do not install and use it in ambient temperature exceeding 35°celsius.
- 3).Do Not install and use the machine in high temperatures and humid environments.

WARNING: TO AVOID A HAZARD DUE TO INSTABILITY OF THE APPLIANCE, IT MUST BE FIXED IN ACCORDANCE WITH THE INSTRUCTIONS.

WARNING: KEEP VENTILATION OPENINGS, IN THE APPLIANCE ENCLOSURE OR IN THE BUILD-IN STRUCTURE, CLEAR OF OBSTRUCTION.

WARNING: DO NOT USE MECHANICAL DEVICES OR OTHER MEANS TO ACCELERATE THE DEFROSTING PROCESS, OTHER THAN THOSE RECOMMENDED BY THE MANUFACTURER.

WARNING: DO NOT DAMAGE THE REFRIGERANT CIRCUIT.  
THIS WARNING IS ONLY APPLICABLE FOR APPLIANCE WITH REFRIGERATING CIRCUITS WHICH ARE ACCESSIBLE BY THE USER.

WARNING:WHEN POSITIONING THE APPLIANCE, ENSURE THE SUPPLY CORD IS NOT TRAPPED OR DAMAGED.

WARNING: DO NOT LOCATE MULTIPLE PORTABLE SOCKET-OUTLETS OR PORTABLE POWER SUPPLIES AT THE REAR OF THE APPLIANCE.

WARNING: INSTALLATION OF THE FITTING AND CHILLER WITH FILTER CARTRIDGE IS ONLY PERMITTED IN FROST-FREE ROOMS ADEQUATE VENTILATION MUST BE ENSURED. IF NECESSARY, PROVIDE VENTILATION GRILLES IN THE FRONT OF THE LOWER CABINET.

**WARNING:DO NOT USE CHILLER UNLESS LEAK DETECTOR IS INSTALLED**



Symbol ISO 7010 W021(2019-07)  
Warning: Risk of Fire/Flammable materials

### **Installation instruction guideline as below**

This appliance is intended to be used in household and similar applications such as

- Staff kitchen areas in shops, offices and other working environments;
- Farm houses and by clients in hotels, motels and other residential type environments;
- Bed and breakfast type environments;
- Catering and similar non-retail applications.

Refrigerant: R600a. This is a highly flammable refrigerant. DO NOT store any aerosols or other flammable substances in the cabinet with the chiller. This unit is not to be serviced by anyone other than a certified technician and in all cases please contact Peppy Taps first as we will replace the unit if there is an issue rather than service.

# Trouble shooting

No	Problem	Possible cause , and What to do
1	Product cannot run normally	Shut off machine, then restart after 5minutes; if not solved, please contact the technician.
2	Too much noise	The standard sound level shall be less than 70db, If loud noise coming from unit, shut off machine.if not solved, please contact the technician. Low temperature less than -3°C; Turn off machine and restart after 5minutes; if not solved, please contact the technician.
3	ERROR CODE"E1"	Thermostat fails; Turn off machine and restart after 5minutes; If not solved, please contact the technician.
4	ERROR CODE"E2"	Thermostat on chilling tank fails; Turn off machine and restart after 5minutes;If not solved, please contact the technician
5	ERROR CODE"E3"	Thermostat on compressor cooling tank fails: Turn off machine and restart after 5minutes; If not solved, please contact the technician.
6	ERROR CODE"E5"	Thermostat on compressor cooling tank show up due to over temperature Turn of machine and restart after few minutes. If not solved, please contact the technician.
7	E4	Contact MANUFACTURER





## **Care & Maintenance**

Important: Do not perform maintenance or cleaning of the boiling water or chiller tank without first turning off and unplugging the power point. Cleaning should be carried out using a non abrasive cleaner. Any abrasive cleaner will scratch the surfaces and potentially take off the markings. For the tap do not use citrus based cleaners. We recommend using warm water with a cloth. Particularly for matte black taps as it will remove the colour and this is not covered under warranty.

## **Contact Details**

For any help needed please call the number below  
Contact us in Australia  
Telephone: (03)9122 0716  
Email:Sales@peppytaps.com.au  
Call us in New Zealand  
Telephone:0800 434 756  
Email:sales@heirloom.co.nz  
[www.peppytaps.com.au](http://www.peppytaps.com.au)