

4IN1 TAP ELECTRONIC PULL OUT

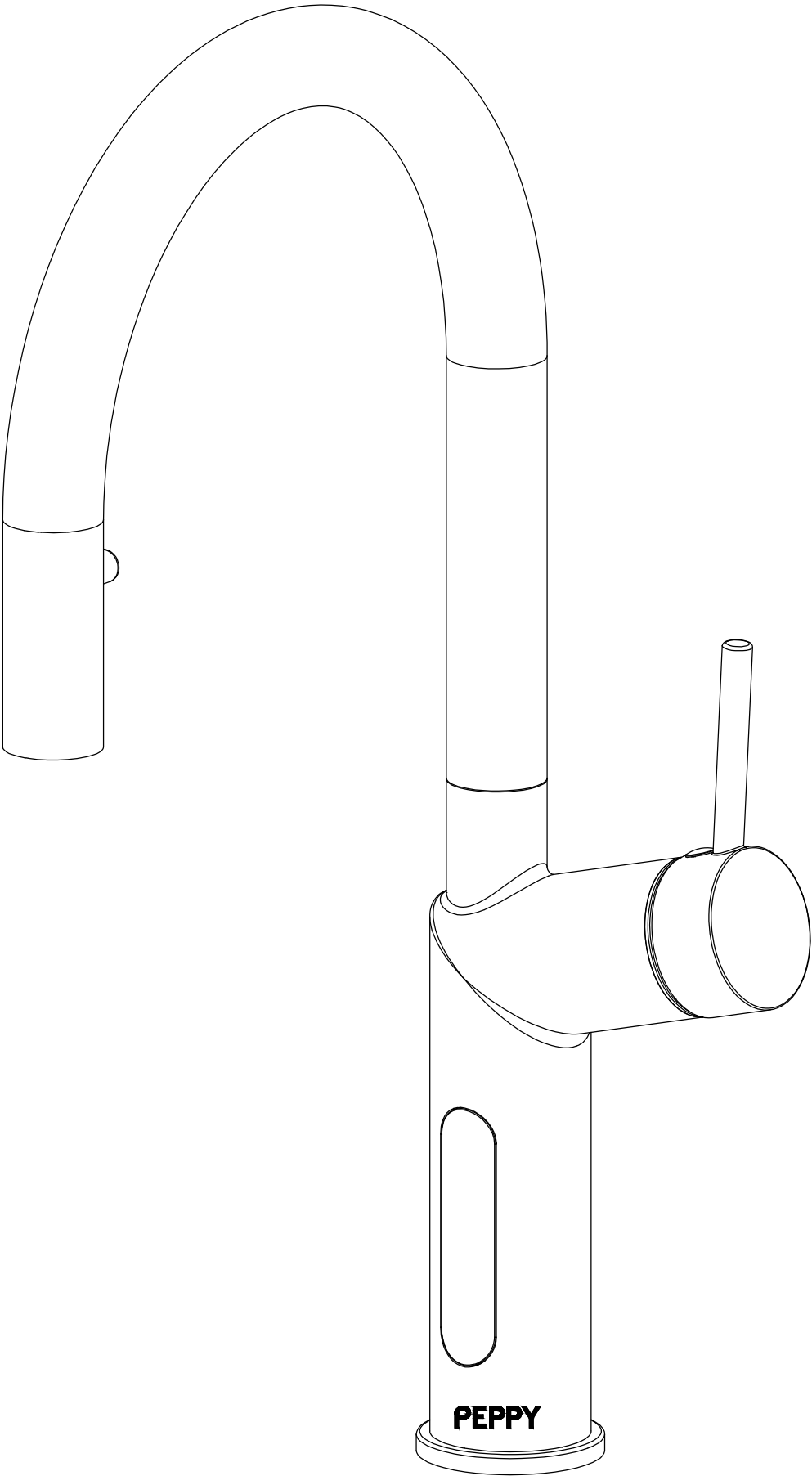

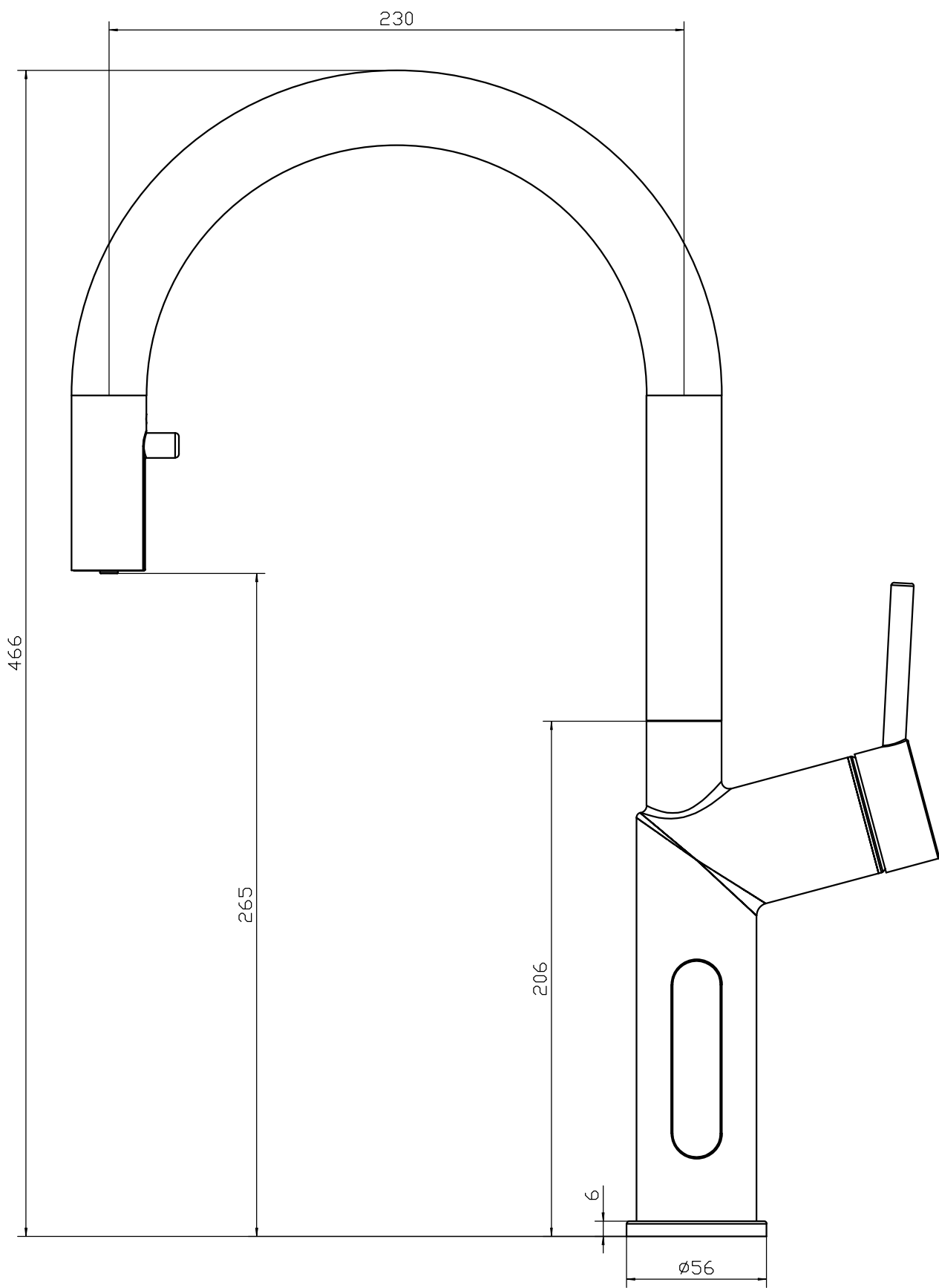

Hole size in Bench for tap is 35mm

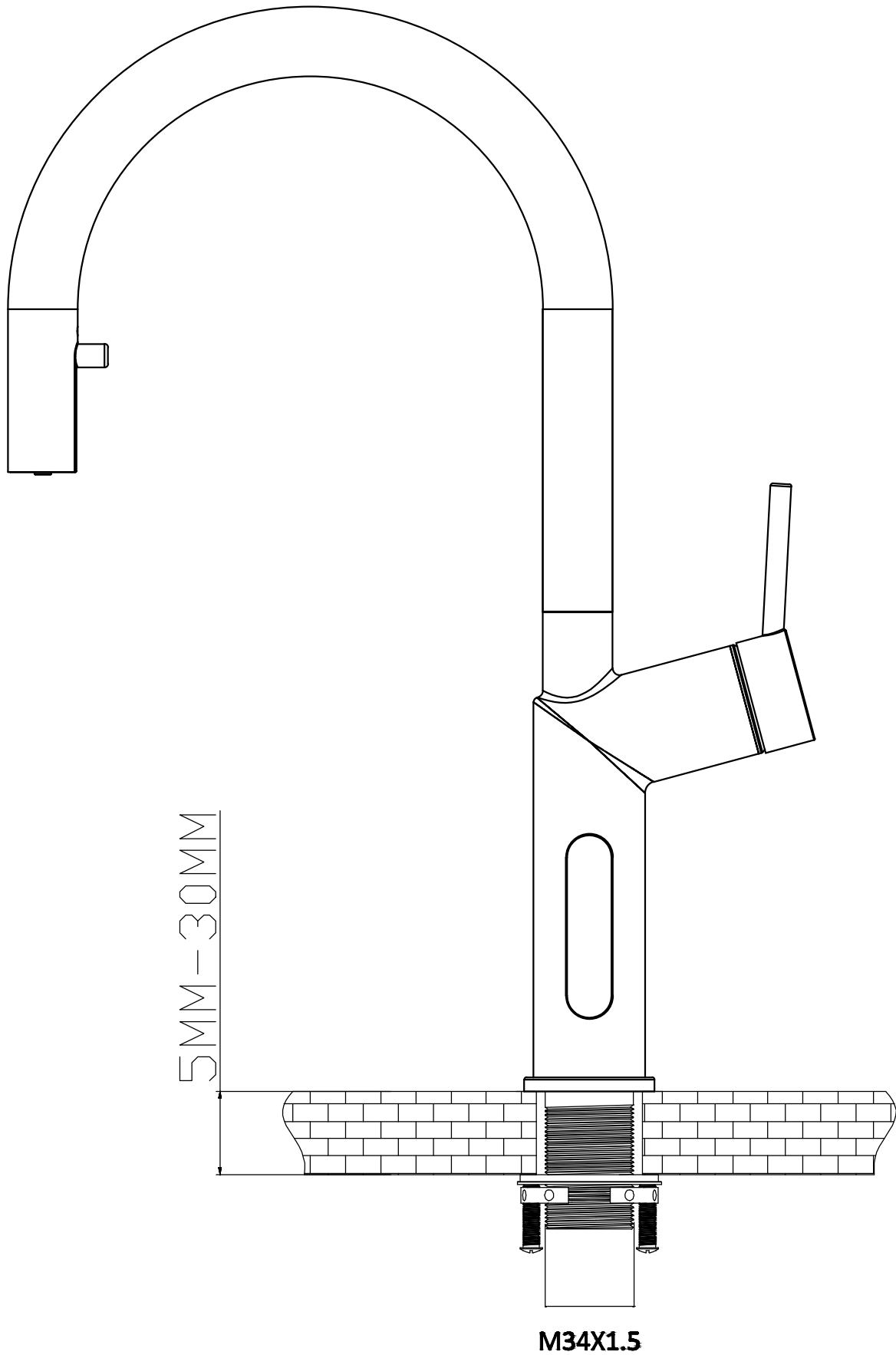

NO	Part Description	Qty	size
A	TAP	1	
B	O-ring	1	
C	Rubber Washer	1	47*32.5*3
D	Metal Washer	1	
E	Mounting nut	1	32*1.5
1	cold flexible hose	1	M8*1-1/2"thread
2	Hot flexible hose	1	M8*1-1/2"thread
3	Mains hot and cold from tap to T adaptor	1	M8*1-Ø1/4" quick fit
4	Hose from boiler outlet to Pullout T incuding clear washer attached	1	M8*1-3/8"thread
5	Hose from cold water supply to pressure limiting valve	1	3/8"thread-Ø1/4" quick fit
6	PE hose from pressure limiting valve to filter inlet	1	Ø1/4"
7	PE hose from filter outlet to T adaptor	1	Ø1/4"
8	PE hose from T adaptor to chiller inlet	1	Ø1/4"
9	PE hose from chiller outlet to Control box chiller water inlet	1	Ø1/4"
10	PE hose from T adaptor to Control box boiling water inlet	1	Ø1/4"
11	PE hose from chiller waste water outlet to saddle drain	1	Ø1/4"
12	Three way connector	1	1/2"female*3/8"male*1/2"male
13	1/4" quick fit T-adaptor	2	Ø1/4" quick fit
14	Pressure Limiting valve	1	Ø1/4" quick fit
15	Neoperl flow limiter	2	1/2" insert
16	Saddle drain	1	Ø1/4" quick fit
17	quick fit connector	1	3/8"thread-Ø1/4" quick fit
18	control box	1	
19	The power adapter	1	
20	PE hose from control box to boiler inlet	1	Ø1/4"
21	PE hose from control box chilling outlet to T adaptor	1	Ø1/4"
22	PE hose from T adaptor to Pullout T	1	Ø1/4"
23	Counterweight	1	
24	Pullout hose T connector	1	3/8"male
25	Leak detector	1	
26	PE hose	1	

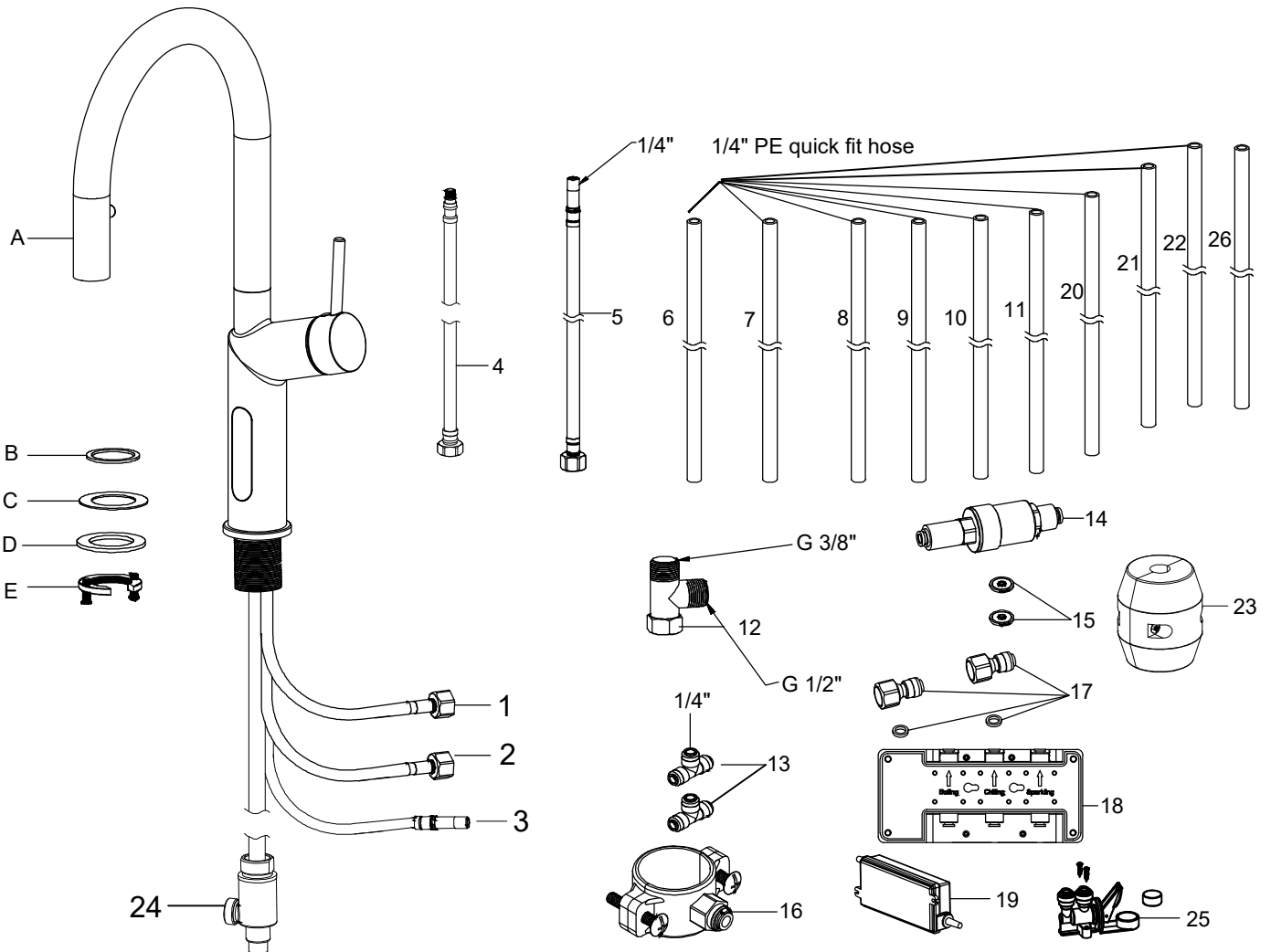

BOILING CHILLED

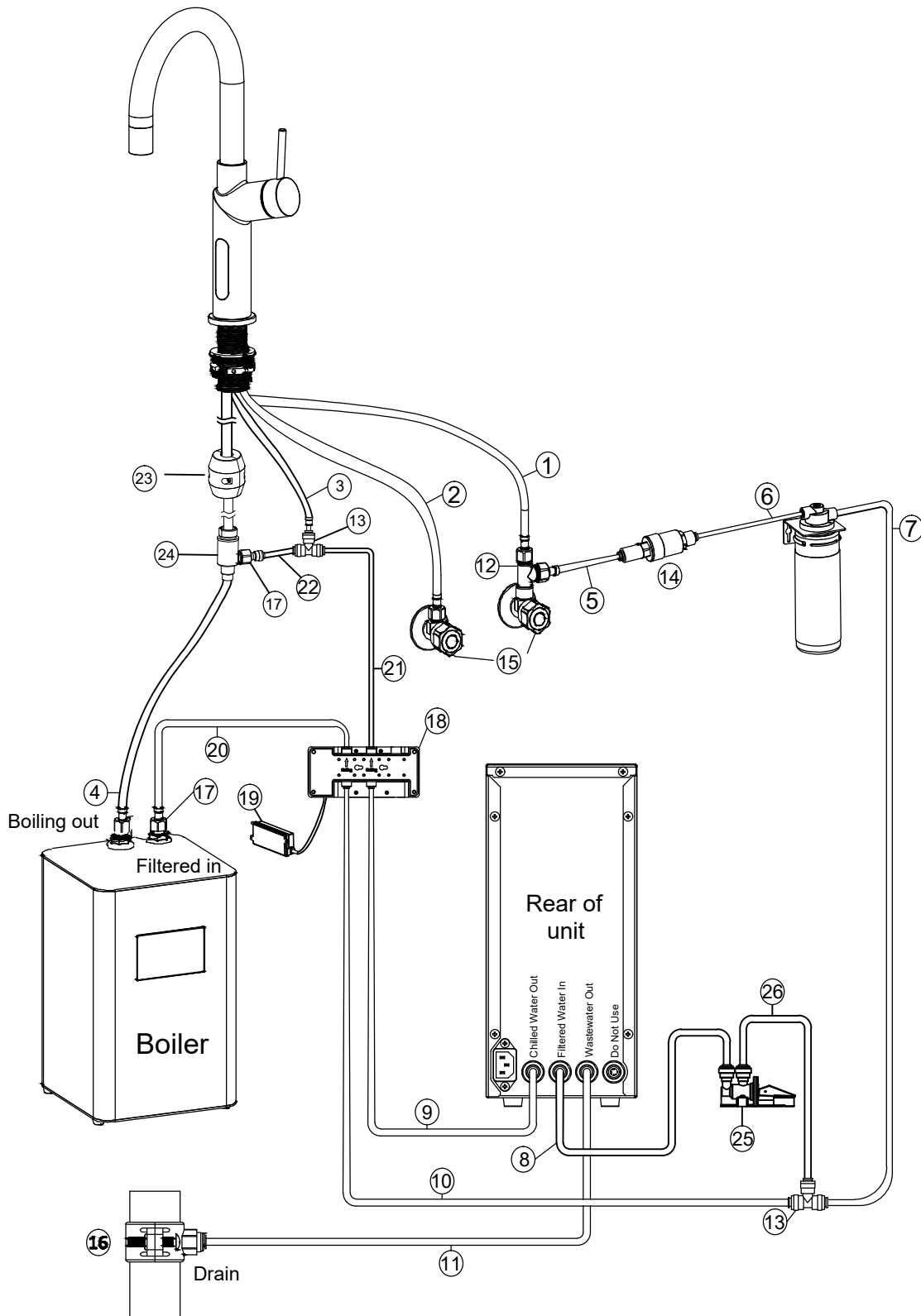

For boiling and filtered water only, connect hose (8) onto the chilled water inlet on the control box.

Note: To run the 4 in 1 tap with a boiler, you require a dedicated 10A dual power point

Product must be installed in accordance with AS/NZS 3500:1 and AS/NZS3500:2 plumbing code of Australia and New Zealand

Note: The use of this may increase bacterial content of the water unless supplementary treatment is provided

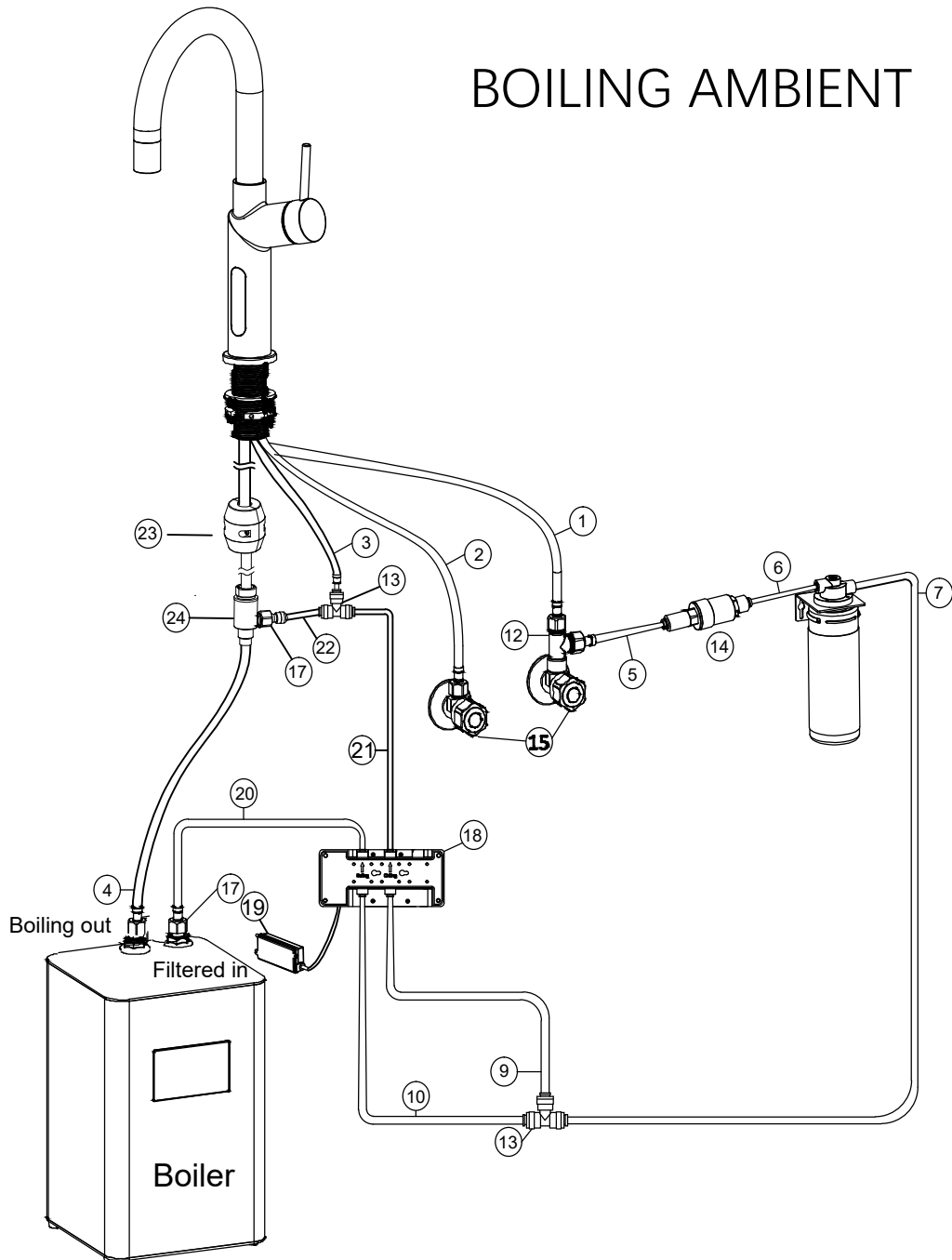

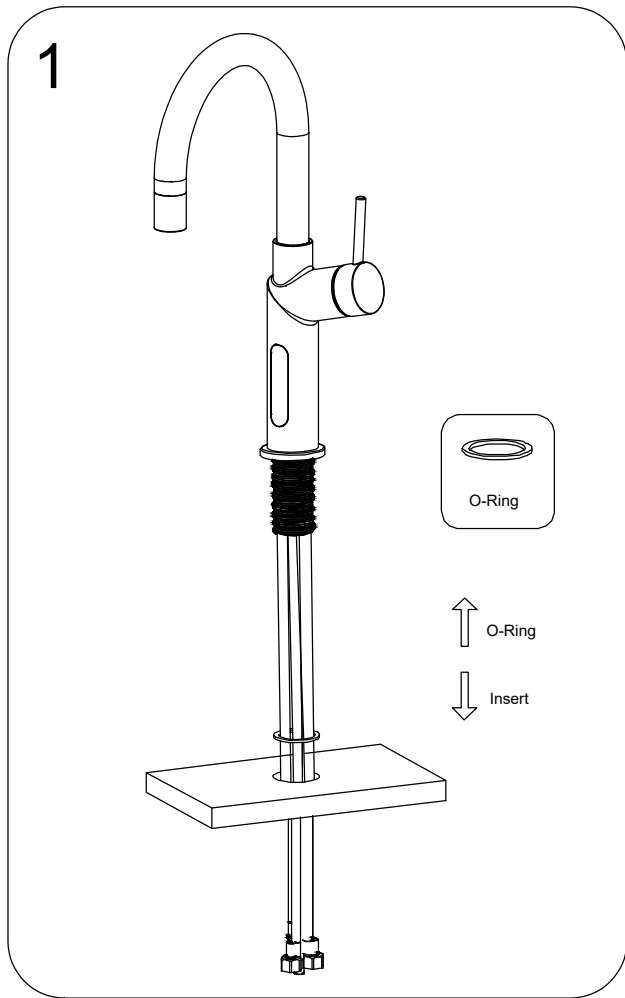

1. Insert the O-ring(B) over the hoses into tap shank, and mount the tap on the sink/Bencht top, see fig.1

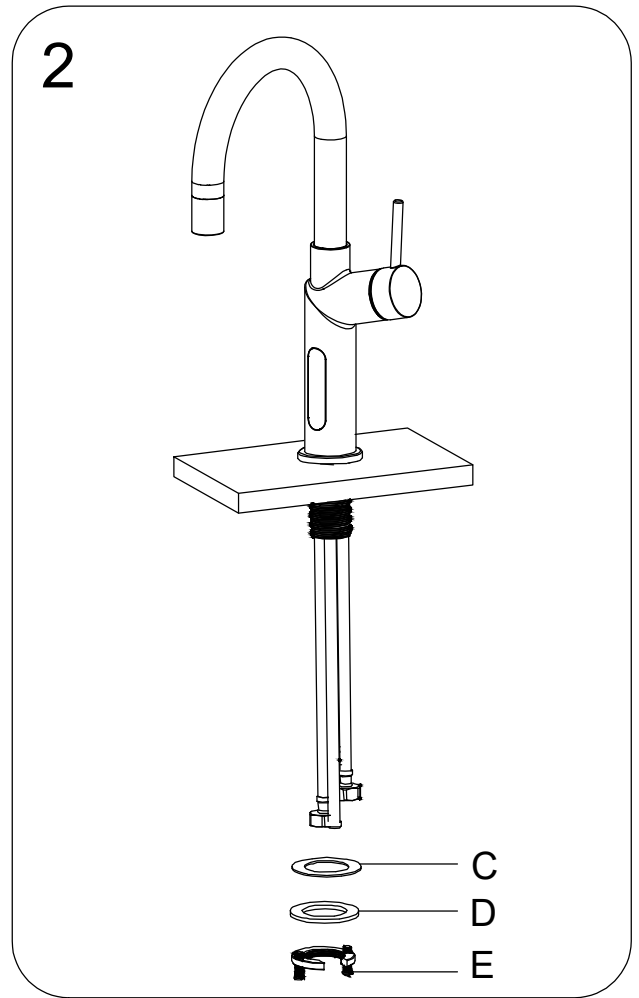

2. Slide the rubber gasket(C) firstly, metal washer(D) secondly, then the mounting nut(E) over the hoses onto the stem, and tighten them firmly, see fig.2

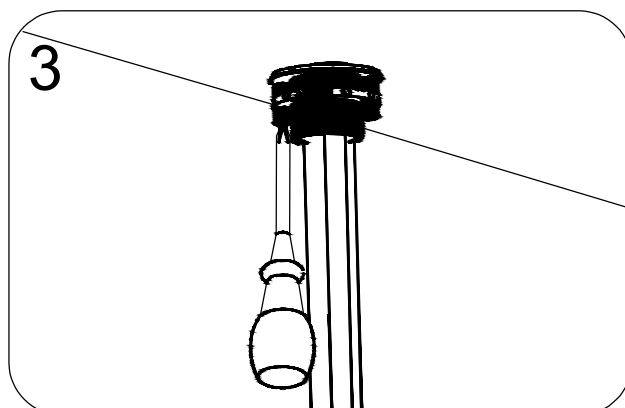

3. Use a Phillips head screw driver to tighten the 2 screws, see fig.3

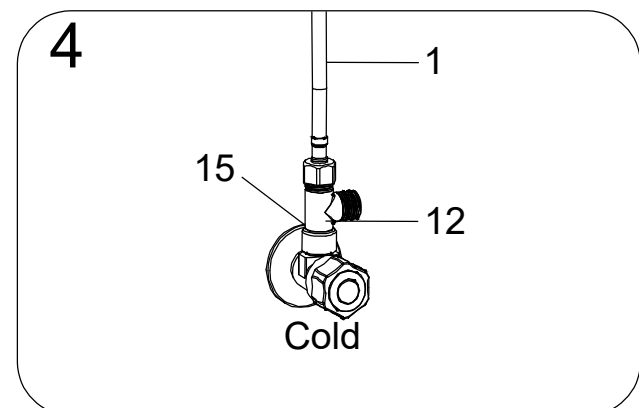

4. Add flow Restrictor(15) into T Adaptor where it connects to mains water. Side with small O-ring on flow restrictor faces towards mains water supply. Connect hose(1) onto T adaptor(12) tighten firmly, see fig.4

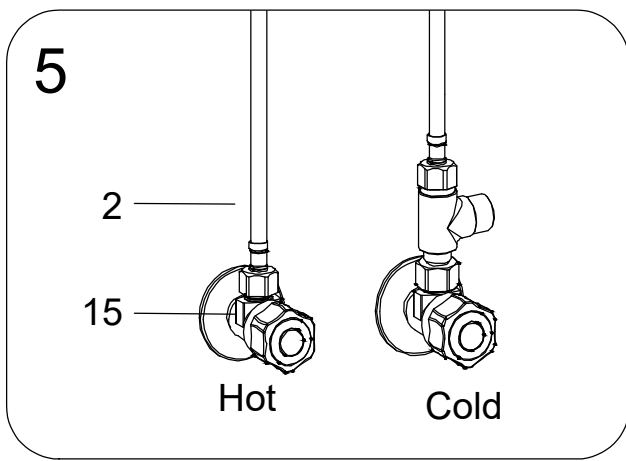

5. Add flow Restrictor(15) into hose(2) (small O-ring faces towards mains water supply) Connect hose(2) to mains water supply, see fig.5

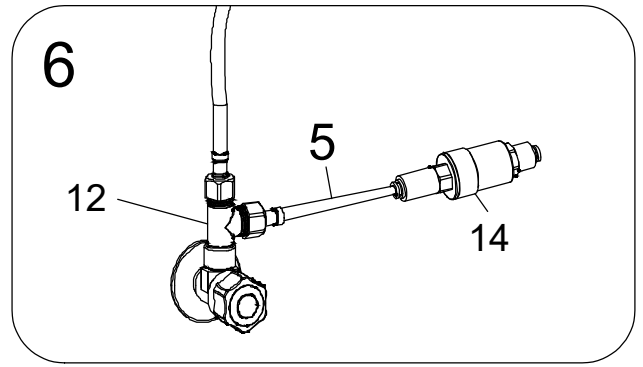

6. Connect hose (5) from 3/8" 3 way connector (12) onto PLV inlet (14) ,see fig.6

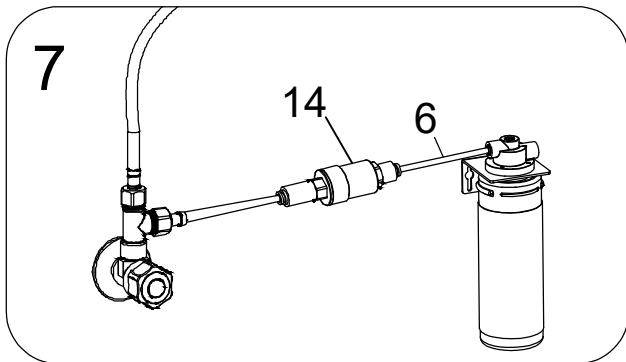

7. Connect 6mm dia hose(6) supplied from PLV outlet to filter inlet, see fig.7

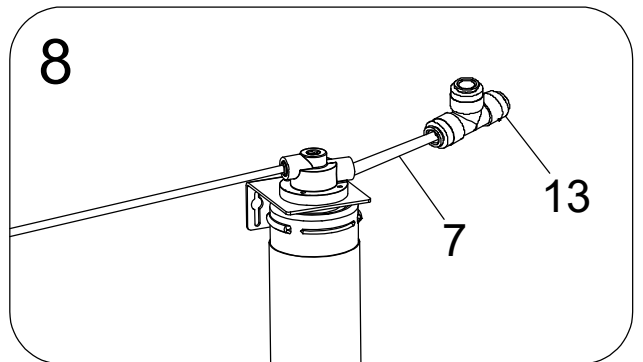

8. Connect 6mm dia hose(7) supplied from filter outlet to T adaptor(13), see fig.8

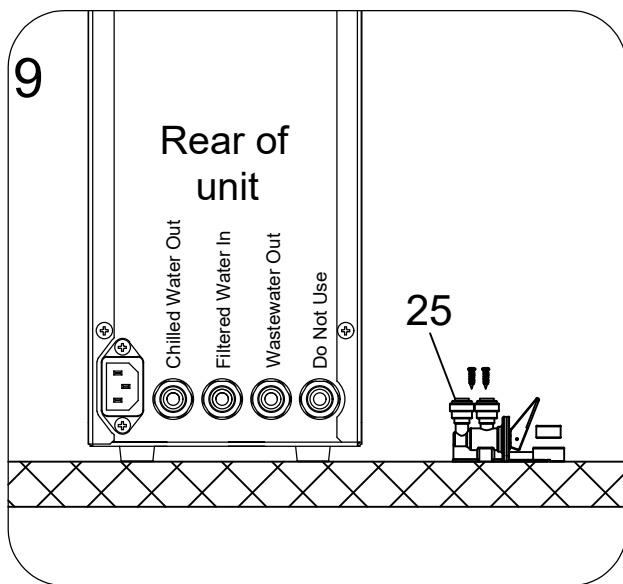

9. Mount the Leak Detector onto the surface area in your cabinet ; Put the compressed textile, see fig.9

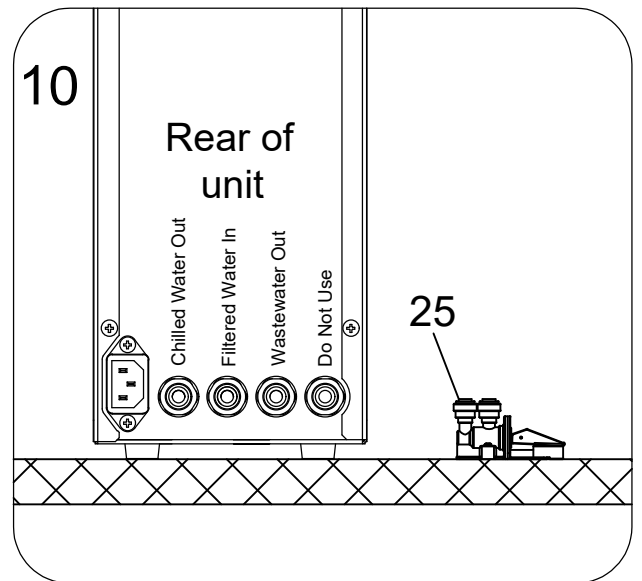

10. Close the cover after after putting in the compressed textile, see fig.10

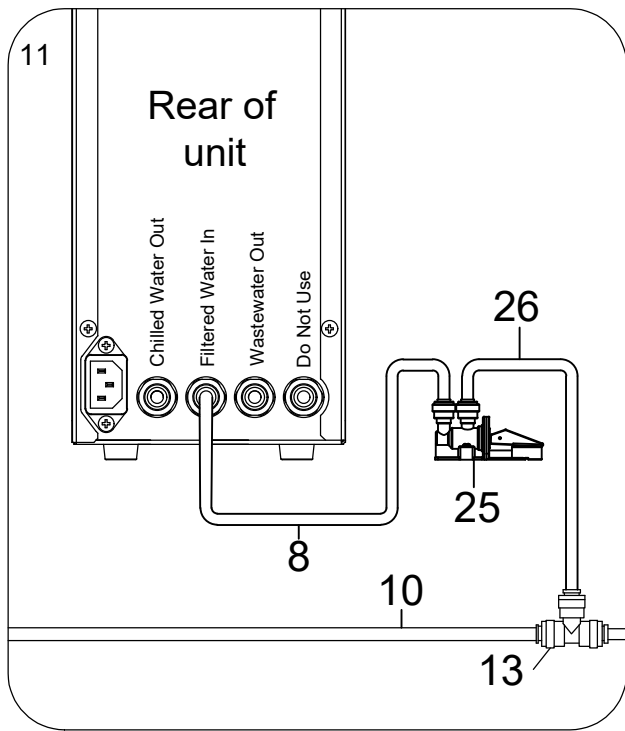

11. Connect 6mm dia hose on both leak Detector' IN&OUT, and fit into chiller filtered water in, see fig.11

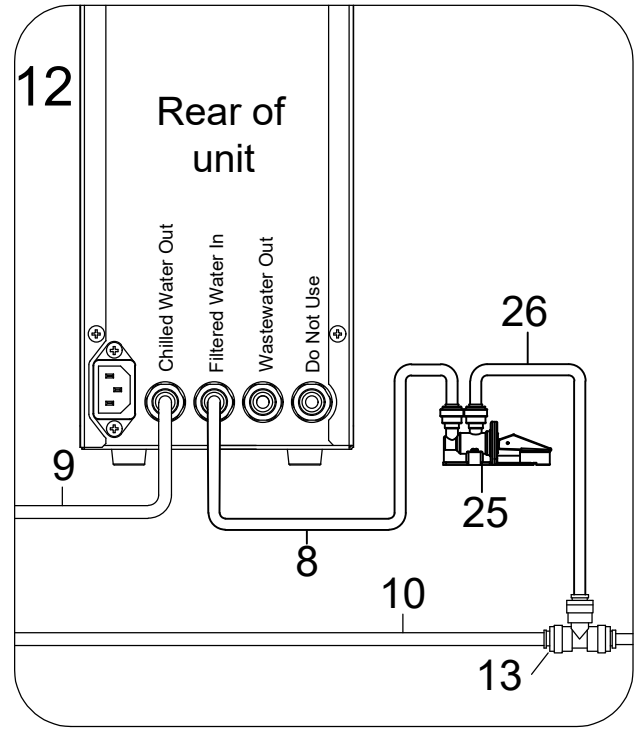

12. Connect 6mm dia hose (9) supplied to chiller filtered water out, see fig.12

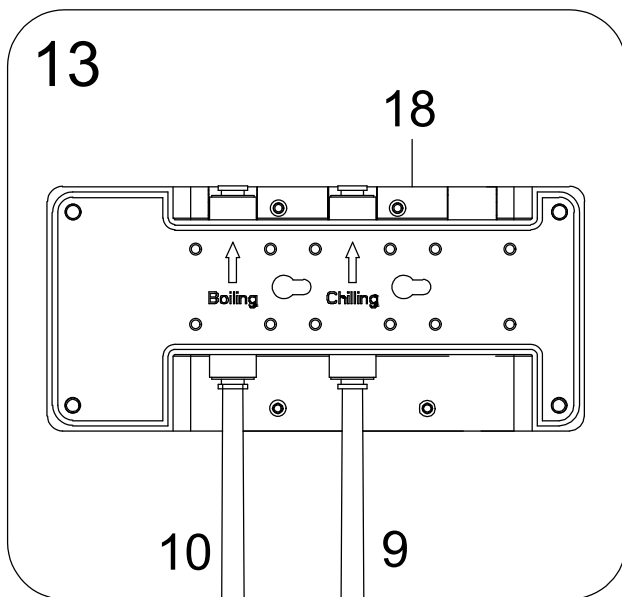

13. Connect 6mm dia hose (9) supplied into chilled water inlet on the control box (18). Connect hose (10) supplied into the boiling water inlet on the control box, see fig.13

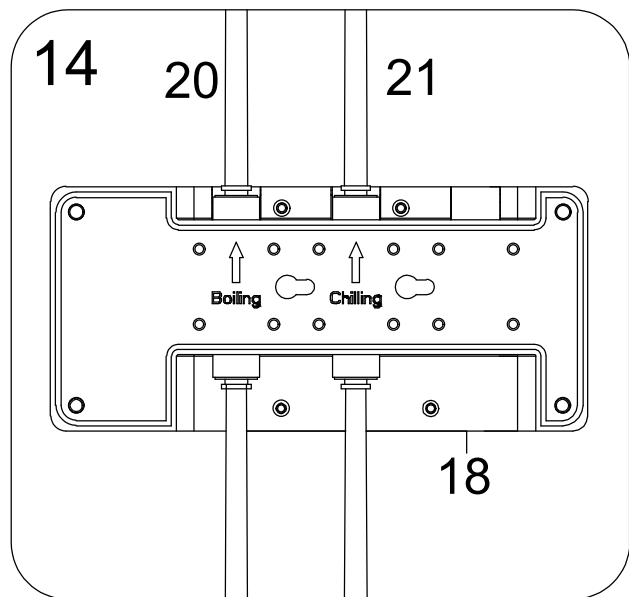

14. Connect 6mm dia hose (20) and (21) supplied to the outlet side of the control box (18) boiling and chilled water, see fig.14

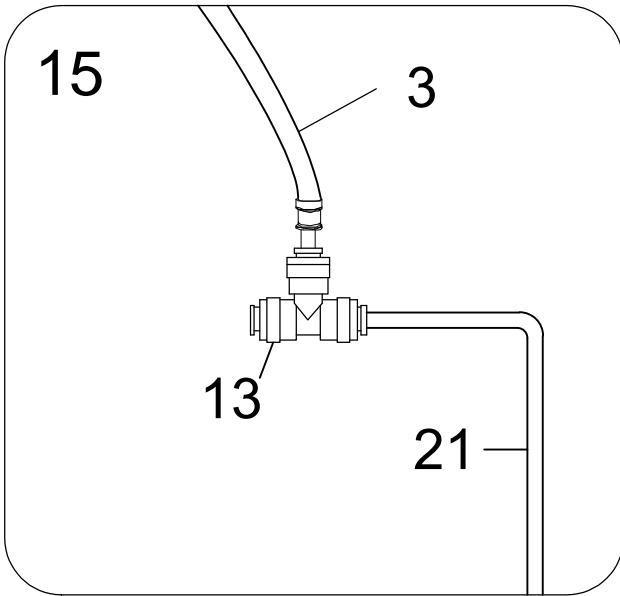

15. Connect 6mm dia hose (21) supplied from chilled water outlet on control box and hose(3) from tap to T adaptor ,see fig.15

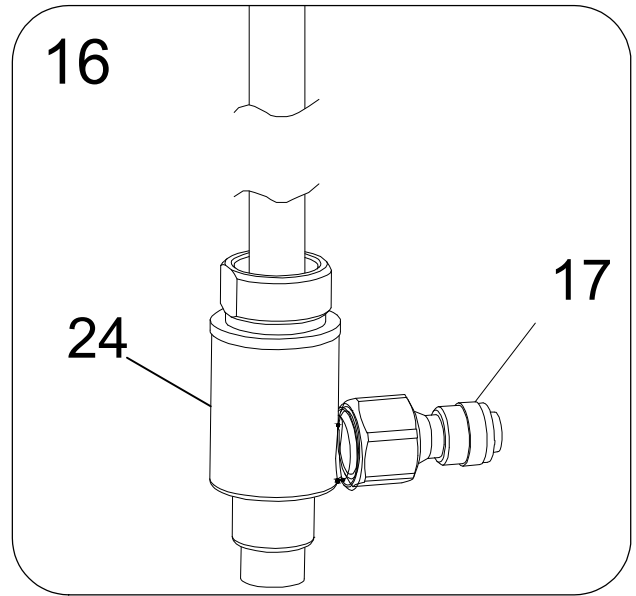

16. Attach quick fit connector (17) supplied onto Pullout Hose T connector (24),see fig.16

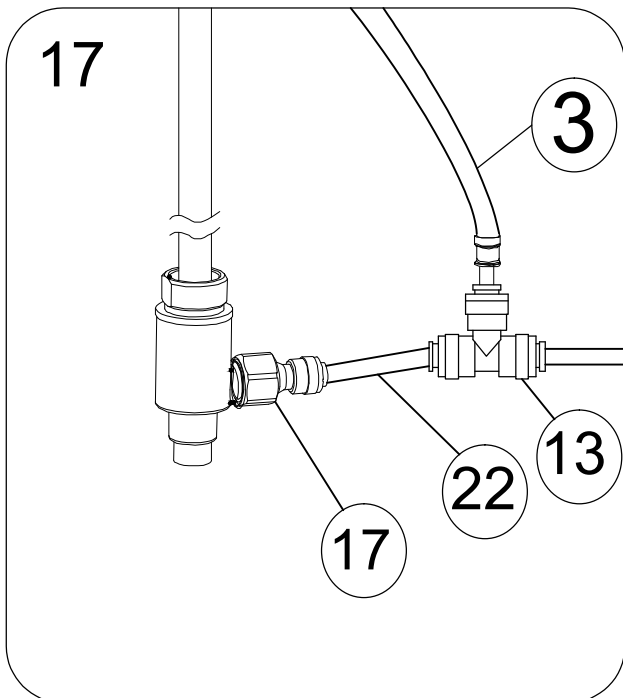

17. Connect 6mm dia hose (22) supplied form T adaptor (13) to quick fit connector(17),see fig.17

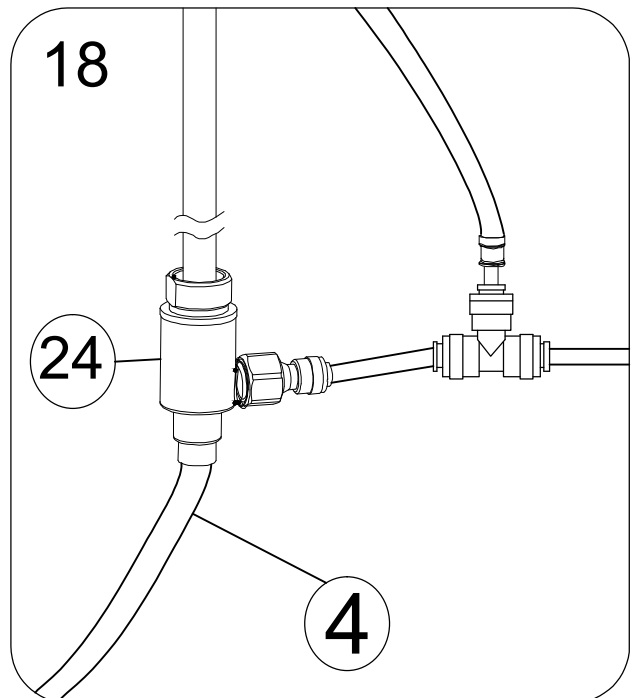

16. Attach screw connection hose (4) supplied to Pull out hose T connector (24) ,see fig.18

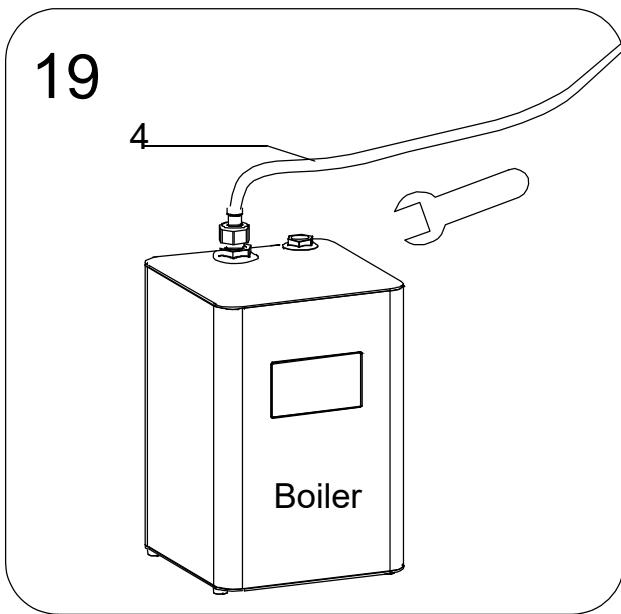

19. Attach screw connection hose(4) supplied from Pull out hose adaptor to boiling water out on boiler (red) Ensure clear washer supplied is used, see fig.19

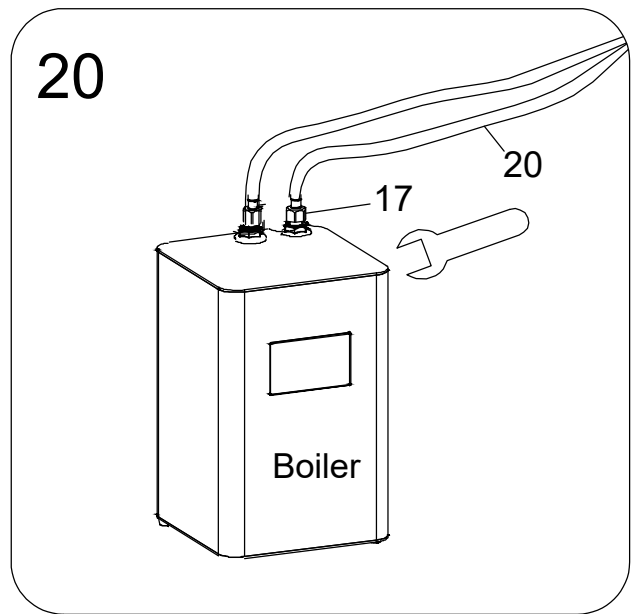

20. Connect 6mm dia hose(20) supplied from control box to quick fit connector(17) on the boiler filtered water in(blue), see fig.20

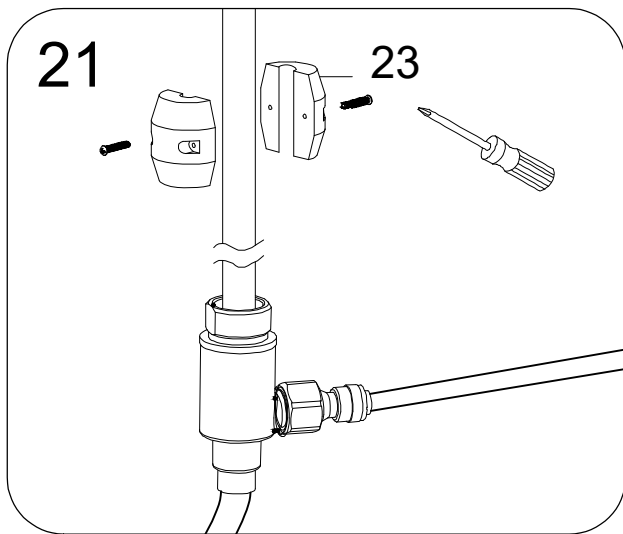

21. Assemble counter weight(23) on this pipe, see fig.21

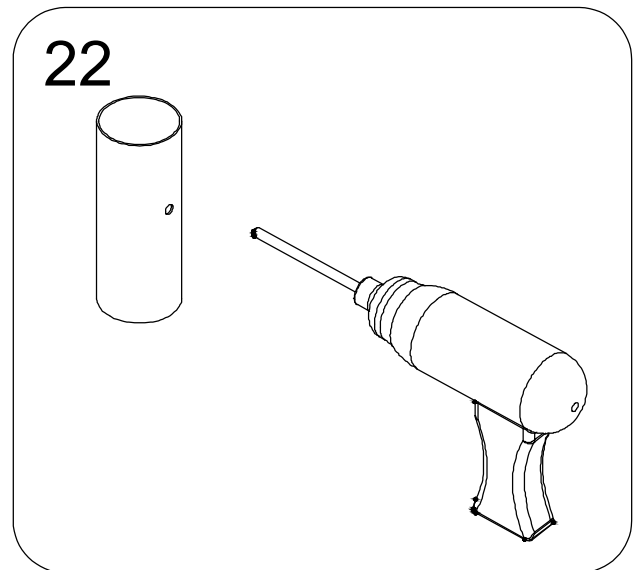

22. Use a drill to drill a 5.5 mm diameter hole on the waste drainage pipe, see fig.22

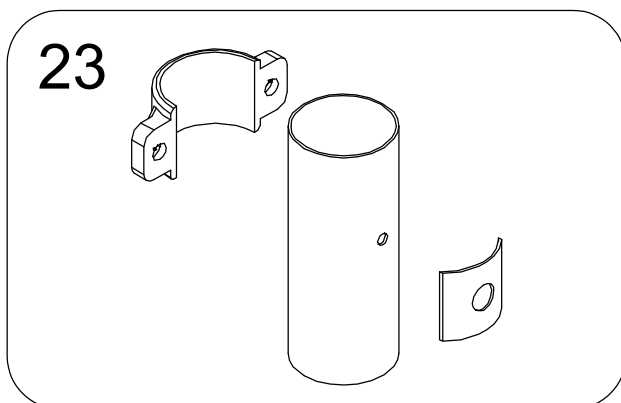

23. Put drain saddle back and front plate onto the pipe, see fig.23

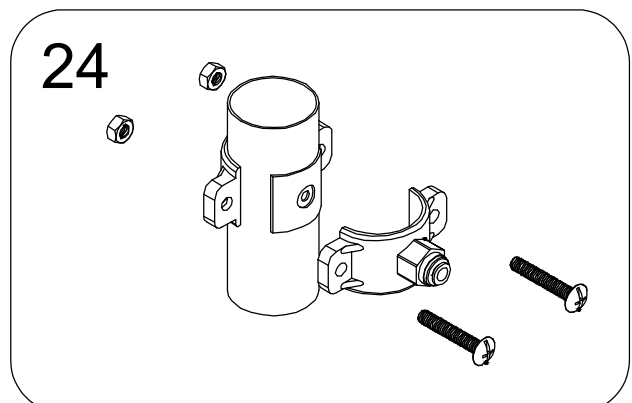

24. Insert screws and tighten nut, see fig.24

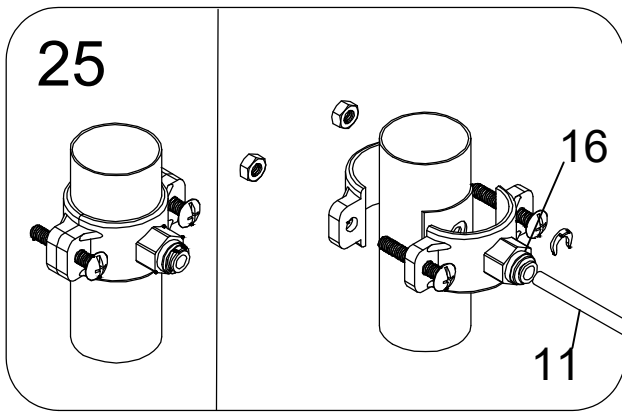

25. After securing the saddle drain, connect the 6mm dia hose (11) to the saddle (16), see fig. 25

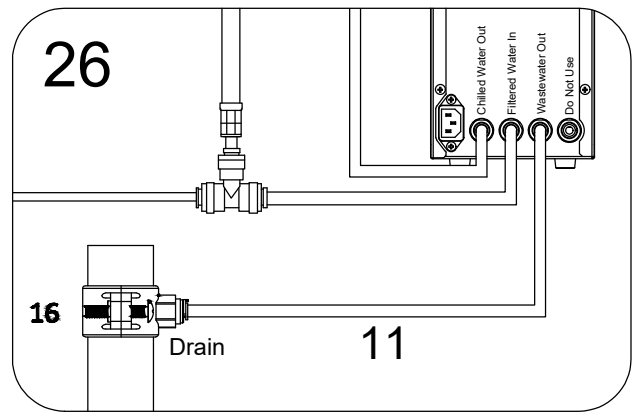

26. Connect 6mm dia hose (11) supplied from the saddle drain (16) to the waste water outlet on the chiller, see fig. 26

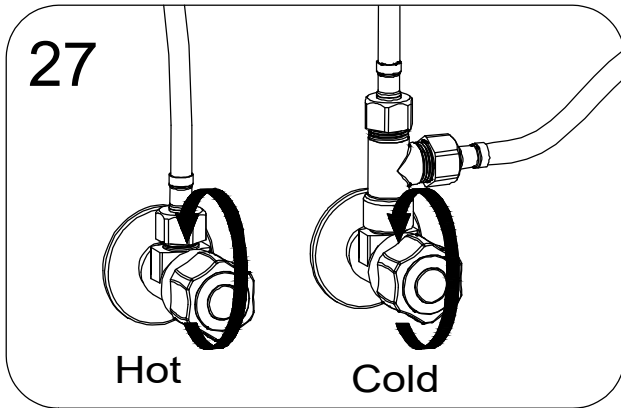

27. Turn on the hot and cold water supply and check all connections for leaks prior to connecting any electrical components., see fig. 27

Note: Isolation valves **MUST** be installed on the hot and cold mains water supply for servicing and maintenance

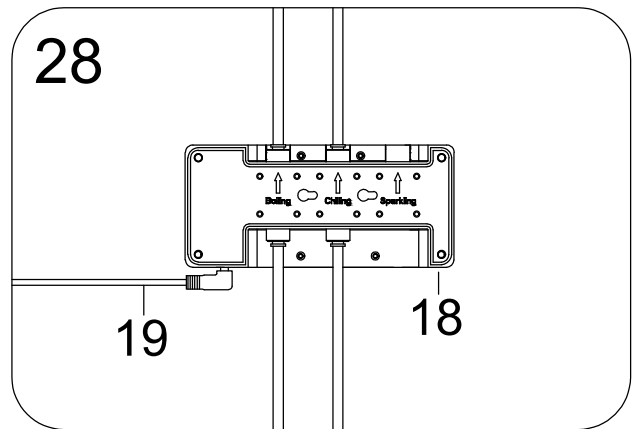

When satisfied that there aren't any leaks, connect the electrical cable (19) from the tap to the control box (18). Lightly press the unlock button on the tap, then press the chilled/filtered button until water starts to flow and purge a minimum of 20L (5 minutes) through the chilled/filtered water tap to purge the filter and check for leaks after the control box. The tap should turn itself off after a few minutes so this procedure will need to be repeated twice.

Once this is completed, completely fill the boiler by unlocking the tap again and holding the boiling water button until water comes out of the tap and continue to hold while checking for leaks in the boiling water connections.

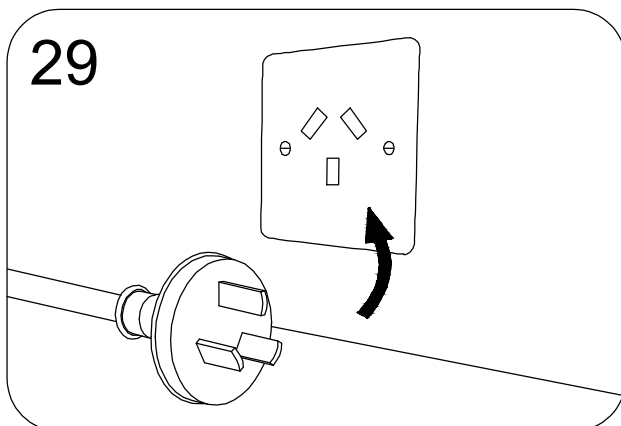

Do not turn on Power until step 28 is complete. Then plug in and turn on.

Note: Installation Must Be As The Plumbing Code Of Australia

COMMISSIONING

It is the installer's responsibility to ensure that your 4 in 1 Electronic Pull Out Mixer Tap is fitted following all prevailing national standards and local water laws. It is important to ensure that the plumbing part of the installation is completed and has been tested to ensure it is free of leaks before any electrical connection is made to the unit. Do not install the appliance in rooms where the temperature may drop to 0°C. The Tap or Boiling Water Tank has been stored prior to installation in a place where the temperature could have fallen below 0°C, Allowed to acclimatise at room temperature for a minimum of one hour prior to connection to a water supply.

Before installing the 4-1 tap it is essential to thoroughly flush through the supply pipes in order to remove any impurities from your system. Failure to carry out this simple procedure could cause problems or damage.

NOTE: Minimum supply pressure for the cold water is 150 KPA and maximum is 500 KPA

You must install isolation valves to both the hot and cold feed pipes in an accessible position. This will help prevent premature failure and ease any future maintenance. All parts should be removed from their packaging and inspected prior to installation.

remove the old tap & clean the ends of the feed pipes using wire wool; the tap hole area should also be free from dirt and sealant.

Positioning the Boiling Water Tank unit and the filter

- The reservoir/heater unit should be positioned on a flat level surface such that:
- There is a minimum air-space of 150mm to each side of the reservoir/heater unit.
- There is a minimum air-space of 25mm to the rear of the reservoir/heater unit.
- Access to any stopcocks, valves, waste traps or other plumbing fittings that may require service is not impeded.

The front display and operating controls are readily accessible and visible.

1. All pipes can be installed without stretching or twisting them.
2. Access to the electrical power socket to be used for this appliance is not restricted .
3. Ensure a fused 10AMP power supply within reach of the power cable, Ensure cable is not stretched. If it is necessary to extend the power cable to reach the nearest suitable socket, this must be done by an electrician. A double GPO will be needed if you are installing a Boiler & Chiller.The tap also requires a GPO for operation
4. The filter should be mounted in a convenient location on a wall or cabinet side, taking into consideration the length and routing of the connecting hoses.

Boiler and Chiller Operation

DO NOT SWITCH ON THE HOT WATER TANK OR CHILLER at this stage until the following has been carried out.

- 1.Run the FILTERED COLD WATER for a minimum of 5 minutes to activate and clean the carbon agency inside the Anti-scaling filter before starting the Hot Water Tank.
- 2.Then Run BOILING WATER for a minimum of 5 minutes.

Taking this small step will prevent any carbon dust from entering the filter. If there is any black coloured water it is harmless and it will clear itself by running the water.

Open all installed water valves to allow water to flow to the 4-1 electronic pull out tap.

For the boiler Press and hold the safety button (White Icon) for 2 seconds, then press and hold the boiling water button (Red icon) until the water flows from the tap spout which indicates the taps reservoir is full. Check all the connections for leaks whilst the water is running. Once checked, release your hand from the red icon.

Any leaking joints must be tightened and the surrounding area dried before connecting the power supply.

ONLY connect the electricity supply to the Hot Water Tank at this stage. Insert the plug into the electricity socket and switch on.

How to control the INSTANT BOILING WATER TANK

- A: On/Off Key
- B: Temperature Key
- C: Heating Display
- D: Set Temperature Indicator
- E: Actual Temperature Indicator
- F: Filter Life Indicator

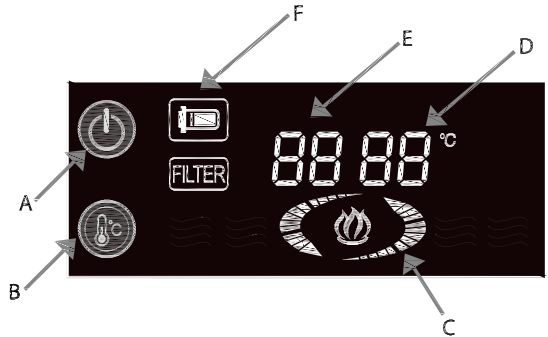

Touch the “on/off” key (A) once to switch the heater on. Press again to turn off.

Scroll through temperature settings using temperature key (B), leave on desired temperature, indicator will flash three times and set temperature indicator (D). Filter life indicator (F) will appear when it is time to change your filter.

A reminder will sound after 6 months and again after 12 hours from the first sound to reset, replace your filter and hold the temperature key (B) for 10 seconds until a single beep sounds and the filter logo will return to full. the “Actual Temperature” indicator (E) shows the actual temperature of the water in the Boiling Water Tank. When the water is heating up, indicator (C) will illuminate and the “Heating” Display (C) will animate. Care and Maintenance Important:

The Warranty Is Void If The Water Filter Is Not Replaced At A Minimum Of 12(twelve) Months From Its First Use. If The System Is Use In The Hard Water Area, Customer Should Consider To Replace The Water Filter In A Shorter Period Before The Twelve Months Period.

Do Not Perform Maintenance Or Cleaning Of The Boiling Water Tank Without First Switching Off The Electricity Supply. Cleaning Should Be Carried Out With A Non-abrasive Cleaner. Any Abrasive Cleaner (including Cif) Will Scratch The Surface And Could Erase The Marking. Exterior Of Your Boiling Water Tank Can Be Cleaned Effectively By Using A Damp Cloth And Mild Detergent. Finish Off By Drying With A Clean Cloth.

Replacement Filters available through retailer

SPECIFICATIONS

Supply	230V ~ 50Hz	Information For Correct Disposal Of The Product In Accordance With The Directive 2002/e. At The End Of Its Working Life This Equipment Must Not Be Disposed Of As Household Waste.it Must Be Taken To A Local Authority Waste Collection Centre Or To A Dealer Providing This Service.disposing Of Electrical And Electronic Equipment Separately Enables Its Components To Be Recovered And Recycled To Obtain Significant Savings In Energy And Resources. In Order To Underline The Duty To Dispose Of This Equipment Separately, The Product Is Marked With A Crossed Out Dustbin.
Power	1500W	
IP rating	X4	
Tank Capacity	2.4 litres	
Immediate draw off	1.7 litres	
Minimum supply pressure	0.15 MPa (1.5 bar)	
Maximum supply pressure	0.5 MPa* (5 bar)	
Hot and cold connections	3/8" BSP	
Approvals	RCM,CE	

*If pressure is above 0.5Mpa(5bar) then a pressure reducing valve is required.

Guarantee

This product is covered by a standards parts & replacement warranty from purchase for 2 years.

If there is a manufacturing defect within the warranty period, we will send spare parts, repair and return the unit or supply a replacement at our discretion. Incorrect installation, frost damage, the consequences of limescale deposits or failure to follow correct commissioning, operating & maintenance instructions are excluded.

Consequential costs such as labour charges or damage to fittings and surroundings are expressly excluded.

NOTE: We will not warrant tank water installations. Must be installed via mains water only.

Filter must be changed at a minimum every 12 months and must be too a specified Peppy Taps filter. If not the warranty is void.

Leak detector must be installed on all models with a chiller.

Commercial warranty is 12 months parts & labour.

If you experience an issue with this product you should firstly contact our service department before taking further action. Experience has shown that issues can often be resolved without the need to return or uninstall the product.

Scope of Use to indicate compliance with the Lead-Free requirements of the National Construction Code Volume 3.

Important Notice On Boiler

Caution: Do Not Use With Water That Is Microbiologically Unsafe Or With Water Of Unknown Quality Without Adequate Disinfection Before Or After The System. Systems Certified For Cystreduction May Be Used On Disinfected Water. That May Contain Filterable Cysts
This Product Can Cause Harm If Installed Incorrectly, The Installation Of Your Instant Hot Water Tap Must Be Carried Out By A Professional Installation Service.

SAFETY INSTRUCTION



Alert symbols identify important safety information to make you aware of potential hazards that can cause property damage or in the severest cases, serious injury or death.

This product is not for outdoor use!

A standard 220/240v grounded 10amp switched electrical outlet is required under the sink for the appliance electrical power

The power outlet must be connected to the 10amp fused plug supplied.

Do not plug in the tank until all water connections have been checked, watertight and the tank has been filled. The tank is filled once water starts to pass out the tap spout.

It is recommended before using the tank, to flush through several litres of water to remove any air in the system when installing.

Please note, that in order to avoid having pressurized boiling water and to comply with Australian bylaw, this is an open vented system. In order to ensure the instant hot water tank delivers the highest quality drinking water and is protected from limescale build up, the water filter must be replaced every 12 months. Failure to do so may invalidate your product warranty.

The instant hot water tank is only intended for use with compatible taps. Using this tank with any other tap will invalidate the warranty.

The instructions are only intended as a guide, if there is any doubt then please contact a certified tradesperson.



Warning-for Continued Safety Of This Appliance It Must Be Installed, Operated And Maintained In Accordance With The Manufacturer's Instructions.

For Open Vented Water Heaters, An Instruction That Any Vent Or Outlet Intended To Remain Open To The Atmosphere Shall Not Be Obstructed.

For Controlled Water Heaters, The Rated Power Input, In Kilowatts, Or The Total Nominal Gas Consumption In Megajoules Per Hour, As Appropriate.

For Uncontrolled Water Heaters(e.g.storage, Auxiliary),maximum Working Pressure, In Kilopascals, And Maximum Energy Input, In Kilowatts Or Megajoules Per Hour.

For Auxiliary Uncontrolled Water Heaters, Maximum Rated Output, In Kilowatts Or Megajoules Hour.

Warning-this appliance May Deliver Water At High Temperature, Refer To The Plumbing Code Of Australia(pca) or New Zealand, Local Requirements and Installation Instructions To Determine If Additional Delivery Temperature Control Is Required.



- + To prevent against electrical shock do not place the hot water tank near or in water or other liquids and install on a flat surface.
- + Do not install in environments above 35°C or exposed to freezing.
- + Can be used by children 12+ or people with learning difficulties if they have been given supervision or instructed on the hazards involved. Do not operate or install electrical connections with wet hands.
- + Do not install the appliance if it appears damaged in any way.
- + Only use power lead supplied with the product. If the power lead is damaged, stop using immediately and contact customer services for a replacement.
- + Do not remove tank casing, this product is not serviceable and should be returned to the manufacturer in the event of a fault.
- + Do not modify the tank or remove the plug as this will invalidate the warranty and could cause serious injury. Designed for Australian 3 pin socket only.
- + If the unit is unused for extended periods of time it should be unplugged, drained, re-filtered and refilled.
- + The external casing can be cleaned with a lint free damp cloth. Do not use any abrasive or corrosive cleaning products as this will damage the surface of the product.
- + Replace the filter every 12 months

Important Notice On Boiler

Below is a list of some of the possible malfunctions.

If the problem cannot be resolved as described, contact the dedicated customer care line(details on back cover).

PROBLEM	POSSIBLE CAUSE	WHAT TO DO
“Set temperature”indicator flashed “E3”	Insufficient water in the tank	Prime the installation as described in the installation instruction below
Water and Steam is spitting from the instant hot water tap spout.	Unit is boiling.	Turn the instant hot water tap handle on and release the water. Adjust the water temperature on the display to a lower setting. Check Aerator not blocked.Re-Prime Bladder to allow correct operation.
Water is not hot.	The electronic instant hot water appliance is unplugged. The electronic display has not been powered up.	Turn the instant hot water tap handle on and release the water. Adjust the water temperature on the display to a lower setting. Check Aerator not blocked.Re-Prime Bladder to allow correct operation.
Water is too hot.	Water temperature setting on display panel is set to high.	Re-set the temperature to the required temperature and confirm the heating up
Water is dripping from the instant hot water tap spout.	The expansion chamber isn't draining the system correctly due to very small draw off of water.Blockage/Restriction after tank.	Draw off 0.5L of water to clear and prime the system. Avoid less than 150ml draw offs of water. Check for kinks in silicon tube. Ensure silicon tube is cut to optimum length. Remove and clean the aerator.
Slow Flow from the spout.	The water filter maybe clogged from impurities in the inlet mains water Blockaged/Restriction after tank.	The water filter must be changed every 12 months; Failure to do this may invalidate your warranty. Draw off 0.5L of water to clear and prime the system, Avoid less than 150ml draw offs of water. Remove and clean the aerator.
Water does not flow immediately	The electronic instant hot water appliance is designed for non-pressurised operation and there will be slight delay till the near boiling water appears.	After a large volume of water has been drawn off there may a slightly longer delay in the water appearing from the instant hot water tap spout.
No Water flows.	Water valves have been turned off. Inlet pipes have become twisted or blocked.	Turn on all the water valves. Ensure the pipes are not twisted or kinked to restrict the flow.
E4		Please call Peppy Taps AUS: 0391220716 NZ: 0800434756

Do Not Perform Maintenance Or Cleaning Of The Boiling Water Tank Without First Switching Off The Electricity Supply. Cleaning Should Be Carried Out With A Non-abrasive Cleaner. Any Abrasive Cleaner (including Cif) Will Scratch The Surface And Could Erase The Marking. Exterior Of Your Boiling Water Tank Can Be Cleaned Effectively By Using A Damp Cloth And Mild Detergent. Finish Off By Drying With A Clean Cloth.

How To Control The Chiller Unit(Skip If You Have Not Installed A chilled Water Unit)

How To Use Chiller Unit

Display panel
"A" (Display panel"on/off"icon) Press and power on or off
"B" "icon to raise to next preset temperature , Temp range: 4°C~14°C
"C" "LED flash, it is flashing when running, it is solid when cooling done "D" : to show the actual temperature "E" :to show the setting temperature



Appliance structure	
Front view	
No	Model: undercounter chill unit
1	Top lid
2	Touching display panel
3	Outlet nozzle-chiller out
4	Water in
5	Wastewater out
6	Do Not Use
7	Appliance outcase
Image	

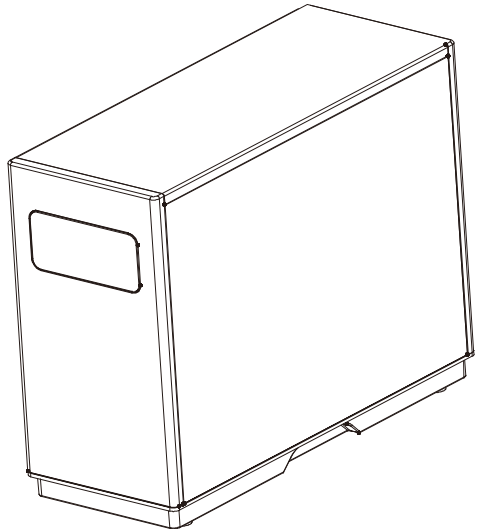
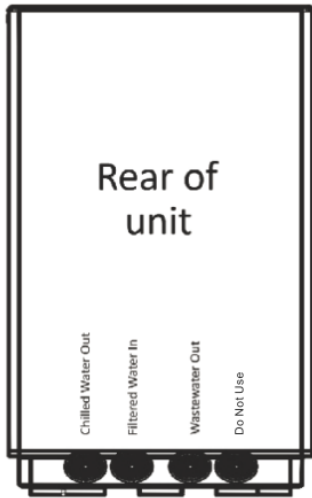

HOW TO USE THE 4-1 Electronic Pull Out Tap

Safety Lock (White Icon) - This is the only icon visible when the tap isn't being used and the safety lock is on. Press lightly and hold for 2 seconds to unlock the boiling and chilled water icons. If no other buttons are pressed within 10 seconds, the tap will lock itself again.

Boiling Water (Red Icon) - Press lightly and HOLD the icon for boiling water. Once released the boiling water will stop

Chilled Water (Blue Icon) - Press lightly and release to start chilled water flow. Press icon again to stop.

Mixed Mains Water, Pull The Large Tap Lever On The Right Hand Side Away From The Body For Cold Water And Towards Yourself For Cold Mains Water. These Instructions Are Only Intended As A Guide, If There Is Any Doubt Then Contact A Certified Plumber Or Service Agent And Avoid Using The Instant Hot Water System Until It Has Been Checked

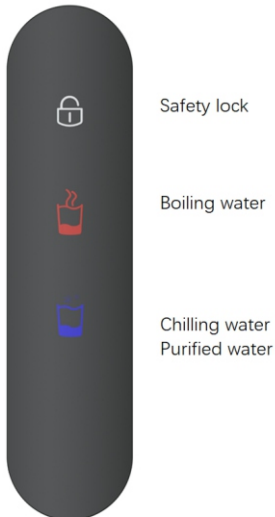

Important Notice On Boiler

1.Safety notes

1) This appliance is not intended for use by persons(including children) with reduced physical sensory or mental capabilities, or lack of experience and knowledge, unless they have been given supervision or instruction concerning use of the appliance by a person responsible for their safety.

Note: Children should be supervised to ensure that they do not play with the appliance

2) If the supply cord is damaged, it must be replaced by the manufacturer, its service agent or similarly qualified persons in order to avoid a hazard.

3) The instructions for appliances connected to the water mains by detachable hose-sets shall state that the new hose-sets supplied with the appliance are to be used and that old hose-sets should not be reused.

2.Product use

1).The chiller Is only suitable for indoor use.

2).Do not install and use It In ambient temperature exceeding 35°celsius.

3).Do Not install and use the machine in high temperatures and humid environments.

WARNING: TO AVOID A HAZARD DUE TO INSTABILITY OF THE APPLIANCE, IT MUST BE FIXED IN ACCORDANCE WITH THE INSTRUCTIONS.

WARNING: KEEP VENTILATION OPENINGS, IN THE APPLIANCE ENCLOSURE OR IN THE BUILD-IN STRUCTURE, CLEAR OF OBSTRUCTION.

WARNING: DO NOT USE MECHANICAL DEVICES OR OTHER MEANS TO ACCELERATE THE DEFROSTING PROCESS, OTHER THAN THOSE RECOMMENDED BY THE MANUFACTURER.

**WARNING: DO NOT DAMAGE THE REFRIGERANT CIRCUIT.
THIS WARNING IS ONLY APPLICABLE FOR APPLIANCE WITH REFRIGERATING CIRCUITS WHICH ARE ACCESSIBLE BY THE USER.**

WARNING:WHEN POSITIONING THE APPLIANCE, ENSURE THE SUPPLY CORD IS NOT TRAPPED OR DAMAGED.

WARNING: DO NOT LOCATE MULTIPLE PORTABLE SOCKET-OUTLETS OR PORTABLE POWER SUPPLIES AT THE REAR OF THE APPLIANCE.

WARNING: INSTALLATION OF THE FITTING AND CHILLER WITH FILTER CARTRIDGE IS ONLY PERMITTED IN FROST-FREE ROOMS ADEQUATE VENTILATION MUST BE ENSURED. IF NECESSARY, PROVIDE VENTILATION GRILLES IN THE FRONT OF THE LOWER CABINET.



Symbol ISO 7010 W021(2019-07)
Warning: Risk of Fire/Flammable materials

Installation instruction guideline as below

This appliance is intended to be used in household and similar applications such as

- Staff kitchen areas in shops, offices and other working environments;
- Farm houses and by clients in hotels, motels and other residential type environments;
- Bed and breakfast type environments;
- Catering and similar non-retail applications.

Refrigerant: R600a. This is a highly flammable refrigerant. DO NOT store any aerosols or other flammable substances in the cabinet with the chiller. This unit is not to be serviced by anyone other than a certified technician and in all cases please contact Peppy Taps first as we will replace the unit if there is an issue rather than service.

VERY IMPORTANT

In any case where the water supply to the Chiller unit is interrupted or turned off, power to the unit MUST also be turned off or disconnected completely.

The Chiller unit uses mains cold water to cool the compressor internally and if left running without water supply it will cause the unit to over heat and shutdown.

The compressor is fitted with an over heat protection device that cannot be reset and the unit will no longer function.

IF THIS OCCURS WARRANTY WILL BE VOID.

Trouble shooting

No	Problem	Possible cause , and What to do
1	Product cannot run normally	Shut off machine, then restart after 5minutes; if not solved, please contact the technician.
2	Too much noise	The standard sound level shall be less than 70db, If loud noise coming from unit, shut off machine.
		Low temperature less than -3°C; Turn off machine and restart after 5minutes; if not solved, please contact the technician.
3	ERROR CODE“E1”	Thermostat fails; Turn off machine and restart after 5minutes; If not solved, please contact the technician.
4	ERROR CODE“E2”	Thermostat on chilling tank fails; Turn off machine and restart after 5minutes;If not solved, please contact the technician
5	ERROR CODE“E3”	Thermostat on compressor cooling tank fails: Turn off machine and restart after 5minutes; If not solved, please contact the technician.
6	ERROR CODE“E5”	Thermostat on compressor cooling tank show up due to over temperature Turn of machine and restart after few minutes. If not solved, please contact the technician.
7	E4	Contact MANUFACTURER

Care & Maintenance

Important: Do not perform maintenance or cleaning of the boiling water or chiller tank without first turning off and unplugging the power point. Cleaning should be carried out using a non abrasive cleaner. Any abrasive cleaner will scratch the surfaces and potentially take off the markings. For the tap do not use citrus based cleaners. We recommend using warm water with a cloth. Particularly for matte black taps as it will remove the colour and this is not covered under warranty.

Contact Details

For any help needed please call the number below
Contact us in Australia
Telephone: (03)9122 0716
Email:Sales@peppytaps.com.au
Call us in New Zealand
Telephone:0800 434 756
Email:sales@heirloom.co.nz
www.peppytaps.com.au